

BRESR 90130

Learning and memory*

Daniel L. Alkon, David G. Amaral, Mark F. Bear, Joel Black, Thomas J. Carew, Neal J. Cohen, John F. Disterhoft, Howard Eichenbaum, Stephanie Golski, Linda K. Gorman, Gary Lynch, Bruce L. McNaughton, Mortimer Mishkin, James R. Moyer Jr., James L. Olds, David S. Olton, Tim Otto, Larry R. Squire, Ursula Staubli, Lucien T. Thompson and Cynthia Wible

FESN Study Group**

(Accepted 4 June 1991)

Key words: Long-term potentiation; Amygdala; Synaptic plasticity; Hippocampus; *Aplysia*; Calcium; Temporal lobe; Neural network; Visual cortex

CONTENTS

1. Introduction. The hippocampus, synapses, circuits and cognition Larry R. Squire (University of California at San Diego, Veterans Affairs Medical Center, San Diego, CA, U.S.A.) and Mortimer Mishkin (NIMH, Laboratory of Neuropsychology, Bethesda, MD, U.S.A.)	194
2. Multiple components of learning and memory in <i>Aplysia</i> : excitatory and inhibitory information processing in a restricted neural network Thomas J. Carew (Department of Psychology, Yale University, New Haven, CT, U.S.A.)	195
3. Calcium-mediated changes in hippocampal neurons and learning John F. Disterhoft, Joel Black, James R. Moyer Jr. and Lucien T. Thompson (Northwestern University Medical School, Department of Cell, Molecular and Structural Biology, Chicago, IL, U.S.A.)	196
4. Use of developing visual cortex as a model to study the mechanisms of experience-dependent synaptic plasticity Mark F. Bear (Brown University, Center for Neural Science, Providence, RI, U.S.A.)	198
5. Is there 'channelling' of information through the intrinsic circuit of the rat hippocampus? David G. Amaral (The Salk Institute, San Diego, CA, U.S.A.)	200
6. Associative pattern completion in hippocampal circuits: new evidence and new questions Bruce L. McNaughton (University of Arizona, Department of Psychology, Tucson, AZ, U.S.A.)	202
7. Possible contributions of long-term potentiation to the encoding and organization of memory Gary Lynch and Ursula Staubli (University of California, Center for the Neurobiology of Learning and Memory, Irvine, CA, U.S.A.)	204
7.1. Introduction	204
7.2. Inhibitors of LTP interfere with rapid learning of new odor cues	204
7.3. Long-term potentiation in the different stages of the olfactory-hippocampal circuit	205
7.4. Mnemonic phenomena in computer simulations of olfactory networks using long-term potentiation-based learning rules	205
7.5. Summary and discussion	206
8. Behaviorally induced changes in the hippocampus David S. Olton (The Johns Hopkins University, Department of Psychology, Baltimore, MD, U.S.A.), Stephanie Golski, Mortimer Mishkin, Linda K. Gorman, James L. Olds and Daniel L. Alkon (NIMH, Laboratory of Neuropsychology, Bethesda, MD, U.S.A.)	206

* These manuscripts were presented at a Study Group on 'Learning and Memory', L.R. Squire and M. Mishkin, chairmen, held in New York City, on November 3, 1990, and sponsored by the Fondation pour l'étude du système nerveux (FESN, 4 rue Bellot, 1205 Genève, Switzerland).

** For a list of participants of this FESN Study Group and the authors' addresses, please see page 215 (at the end of this article).

Correspondence: L.R. Squire, University of California at San Diego, Department of Psychiatry (116), Veterans Affairs Medical Center, 3350 La Jolla Village Drive, San Diego, CA 92161, U.S.A. Fax: (1) (619) 552-7457, or: M. Mishkin, Laboratory of Neuropsychology, NIMH, Building 9, Room 1N107, 9000 Rockville Pike, Bethesda, MD 20892, U.S.A. Fax: (1) (301) 402-0046.

8.1. Introduction	206
8.2. Protein kinase C and memory: a brief review	206
8.3. Acetylcholine and memory: a brief review	207
8.4. Protein kinase C, high-affinity choline uptake and spatial memory	208
9. A snapshot without the album	
Howard Eichenbaum, Neal J. Cohen, Tim Otto and Cynthia Wible Wellesley College, Department of Biological Sciences, Wellesley, MA, U.S.A.)	209
9.1. Introduction	209
9.2. Hippocampal representation in odor discrimination learning	210
9.3. Hippocampal representation in place learning	211
9.4. Isolated 'snapshots' preserved in the absence of normal hippocampal system function	212
9.5. The kind of memory representation supported by the hippocampal system	213
9.5.1. How does the hippocampal system process memories?	213
9.5.2. Where are the memories stored?	214
9.6. Does the snapshot analogy apply equally well to preserved memory in amnesic monkeys and humans?	214
List of participants	215
References	216

1. Introduction. The hippocampus, synapses, circuits and cognition

Larry R. Squire and Mortimer Mishkin

The articles that follow are summary papers from a meeting in New York City on November 3, 1990, sponsored by the Fondation pour l'Etude du système nerveux (FESN). In the tradition of FESN, this meeting was held 18 months after a larger meeting in Geneva, which considered the topic of learning and memory at the level of neural networks and brain systems. At the earlier meeting, participants discussed the neural organization of the kind of memory that is impaired in human amnesia, particularly the medial temporal-lobe (limbic) components of this memory system (Squire, Mishkin and Shimamura, Ref. 138a). During the past decade, this kind of memory has been fruitfully studied in humans as well as in rodent and non-human primate models of human amnesia. At the follow-up meeting, participants focussed their discussions on cellular and synaptic plasticity, especially in the hippocampal formation and on possible links between physiology, biochemistry and behavior. Examples of neural plasticity in the invertebrate *Aplysia* and in mammalian visual cortex were also discussed. Carew presents an analysis of behavioral sensitization as well as recently discovered inhibitory processes in *Aplysia*. Distenhof et al. discusses eye-blink conditioning in the rabbit, which under some training conditions depends on the integrity of the hippocampus. Bear describes plastic-

ity in the visual cortex following monocular deprivation as a model system for investigating the neurobiology of synaptic change. Amaral describes the intrinsic anatomical organization of the hippocampus, which leads to a revision of the classic 'lamellar' hypothesis and to a view that emphasizes its 3-dimensional organization. McNaughton summarizes current understanding of place cells in the hippocampus and the phenomenon of long-term potentiation, in the context of behavioral learning and memory. Lynch and Staubli consider the mechanisms of long-term potentiation-induction, expression and maintenance. Olton et al. report on changes in hippocampal choline uptake and protein kinase C distribution following learning that is known to depend on the integrity of the hippocampus. Eichenbaum et al. present information about place cells and unit activity in hippocampus that is relevant to behavior and through behavioral analysis shows how the kind of memory that depends on hippocampus might be distinguished from other kinds.

These approaches, taken together, describe some of the progress that has been made in understanding the function of the hippocampus, and they emphasize the value of collecting information with a variety of techniques and at several levels of analysis.

2. Multiple components of learning and memory in *Aplysia*: excitatory and inhibitory information processing in a restricted neural network

Thomas J. Carew

Simple systems such as the marine mollusc *Aplysia* afford several advantages for the analysis of information processing in a well defined neural network. An illustrative example is the siphon withdrawal reflex of *Aplysia*. On a behavioral level, this simple reflex exhibits a variety of forms of learning, ranging in complexity from non-associative processes such as habituation, dishabituation and sensitization, to associative processes such as Pavlovian conditioning. Moreover, these diverse forms of learning can exist in both a short-term form, lasting minutes to hours and a long-term form, lasting days to weeks. Thus this simple behavioral system is capable of a relatively wide range of information processing^{21,22,66}. On a cellular level, the siphon withdrawal reflex is mediated by a rather simple neural circuit in which several elements have been identified as unique individuals or as members of small, identifiable classes of neurons (see Ref. 51 for example). Therefore, this simple reflex is well suited for an analysis of the specific roles particular circuit elements play in different forms of information processing.

Most of the forms of learning examined thus far in the siphon withdrawal system have involved facilitation of reflex responding^{24,23,64}. However, recently our laboratory as well as others found that the siphon withdrawal reflex is subject not only to facilitatory modulation, but to inhibitory modulation as well^{78,90,92,93}. Specifically, a commonly used unconditioned stimulus, tail shock, which is known to produce reflex facilitation in a variety of forms of learning, is now known to produce transient inhibition of reflex responding. We are interested in analyzing the cellular loci and mechanisms underlying this inhibitory process, both from a neurobiological perspective, since inhibition is another important form of modulation in the reflex, and from a theoretical perspective, since inhibitory processes are known to play a major role in several forms of learning exhibited in higher animals.

As first steps in our cellular analysis of the inhibition produced by tail shock, we have focussed our attention on interneuronal processing in the circuit for siphon withdrawal. For example, we have shown that a single identified inhibitory interneuron, cell L16 (Ref. 65), is *causally* related to the inhibitory process¹⁷⁰. Specifically, we found that: (1) L16 fires briskly in response to tail shock; (2) direct intracellular stimulation of L16 alone can produce significant inhibition of reflex input to si-

phon motor neurons; and (3) voltage clamping L16 to prevent its firing in response to tail shock significantly reduces (and in some cases abolishes) tail-shock induced inhibition of reflex input to the motor neurons¹⁷⁰. As illustrated in Fig. 1, neuron L16 has extensive connections throughout the circuit for siphon withdrawal, producing inhibition at sensory, interneuronal and motor levels^{51, 65}. Thus, this neuron appears to be in an excellent position to contribute significantly to inhibitory modulation of the reflex. We have also identified several other interneurons in the circuit that appear to contribute to the inhibitory process. Thus it is possible to specify in cellular detail the contribution of specific elements and small interactive networks in mediating inhibitory modulation of the circuit for siphon withdrawal.

In parallel to the cellular approach described above, we have begun to construct a biologically realistic computational model of the circuit for siphon withdrawal. We feel that such a computational approach, in tandem with a cellular analysis, can contribute significantly to fully analyzing the information processing capacity of this simple reflex system. Since it is possible to construct a model based on known cellular parameters, synaptic weights and dynamic interactions among identified ele-

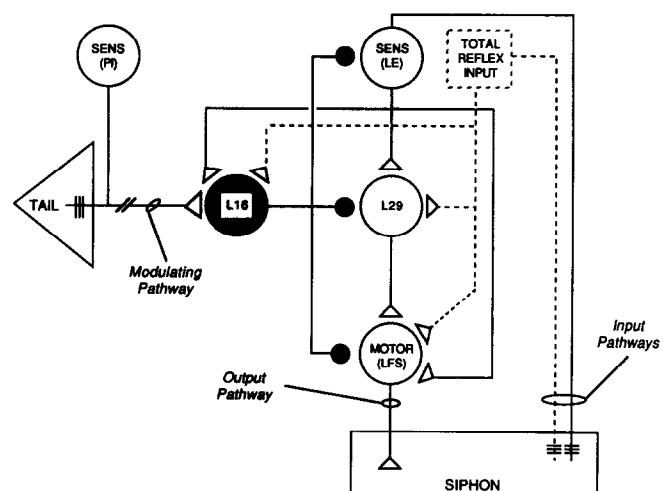

Fig. 1. The inhibitory interneuron L16 (shaded neuron) makes extensive connections in the siphon withdrawal circuit. An extremely simplified circuit is shown comprised of two input pathways (identified LE sensory neurons and the remaining net reflex input), a single excitatory interneuron (L29) and an identified siphon motor neuron (LFS). Tail input (mediated by identified pleural sensory neurons) produces reflex inhibition, in part by activation of L16.

ments in this simple reflex, the neural circuit mediating siphon withdrawal may provide a unique opportunity to construct a comprehensive model of information pro-

cessing in a restricted neural network that both generates an adaptive behavior and is subject to extrinsic excitatory and inhibitory modulation involved in learning.

3. Calcium-mediated changes in hippocampal neurons and learning

John F. Disterhoft, Joel Black, James R. Moyer Jr. and Lucien T. Thompson

Associative learning is accompanied by a number of changes in brain, many mediated by calcium. We have used eyeblink conditioning, a well described learning task in both animals and humans⁵⁷, to elucidate some of these changes. Our studies have focused on the hippocampus, a temporal lobe structure in mammalian brain known to be important for storage of new information during learning. We have recently focused on the trace eyeblink conditioning paradigm, which requires intact hippocampal function for its successful acquisition¹⁰⁷, because of our interest in hippocampal involvement in associative learning. Hippocampal neurons show enhanced firing rates which are correlated with behavioral acquisition and which precede the appearance of conditioned responses in the sequence of learning¹⁸. We have shown

that CA1 pyramidal neurons recorded in slices prepared from conditioned rabbits have reduced calcium-mediated afterhyperpolarizations, a potential cellular mechanism for their enhanced activity *in vivo*^{31,34,39}.

Aging animals and humans show deficits in many learning tasks, including eyeblink conditioning^{60,166}. The aging hippocampus undergoes a variety of alterations, some of which may contribute to the behavioral learning deficits. Examples of aging-related changes include increased calcium-mediated afterhyperpolarizations in CA1 pyramidal neurons⁷⁹ and altered intracellular calcium buffering⁷⁴. These data suggest that aging hippocampal neurons may have difficulty reducing their calcium-dependent afterhyperpolarizations to increase their excitability, an apparent requirement during learning.

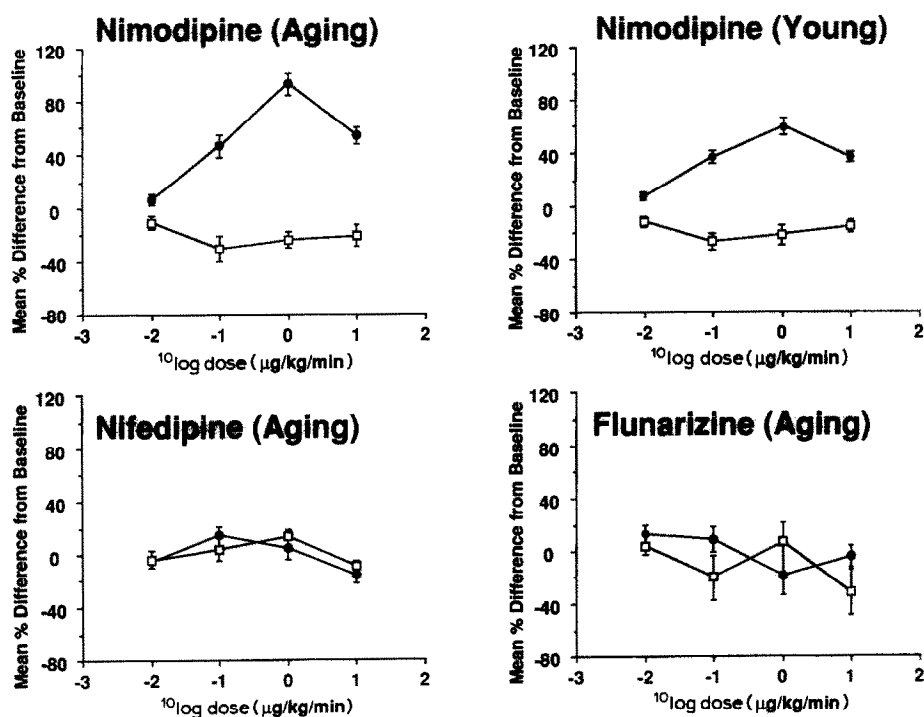

Fig. 2. Dose-response curves showing the effects of calcium-channel blockers on single-neuron activity in the CA1 subfield of dorsal rabbit hippocampus. Of the antagonists tested, only nimodipine (a 1,4-dihydropyridine which readily crosses the blood-brain barrier) affected the mean spontaneous firing rates of pyramidal cells (●) and slightly depressed the firing of θ cells (□), neither nifedipine (a less lipophilic dihydropyridine) nor flunarizine (a diphenylalkylamine) had significant effects on either cell type in aging rabbits. The L-type calcium-channel blocker nimodipine enhanced the spontaneous firing rates of pyramidal neurons in aging animals to a significantly greater degree than in young animals, an effect which may be mediated by deficits in calcium homeostasis as a result of aging. The enhancement of pyramidal cell firing rates seen in both groups was greatest at the behaviorally effective dose of 1.0 $\mu\text{g}/\text{kg}/\text{min}$ *i.v.*

We therefore evaluated the effect of administration of nimodipine, a dihydropyridine calcium channel blocker, on conditioning in aging rabbits. We found that aging rabbits treated with intravenous nimodipine learned the eyeblink conditioning task as quickly as young controls^{36, 37}. In subsequent studies, we have shown that oral nimodipine also enhances eyeblink conditioning learning rates in aging animals¹⁴⁷ as well as reversing aging-related alterations in open field behavior³⁷. Nimodipine seems to have a particular propensity for behavioral improvement in aging animals in learning paradigms, including those which are thought to be hippocampally dependent, as well as on measures of more general sensorimotor skill¹³³.

Our working hypothesis is that nimodipine facilitates eyeblink conditioning via its action on hippocampal neurons. In our behavioral studies, we deliver the dihydropyridine calcium antagonist to the intact animal systemically, using either intravenous or oral administration. Previous studies indicate that nimodipine is extremely lipophilic, tends to cross the blood-brain barrier readily and that it binds with high affinity to the hippocampus in rats when given systemically¹⁵⁵. We have recently done 3 types of experiments designed to evaluate the possibility that nimodipine has direct action on hippocampal neurons.

First, we asked whether systemic nimodipine treatment affected hippocampal neuronal activity. Nimodipine delivered intravenously strongly enhanced the firing rate of single hippocampal pyramidal cells recorded extracellularly *in vivo* (Fig. 2 (Ref. 152)). The maximal effect was seen at the behaviorally most effective dose. The effect was also significantly larger in aging animals

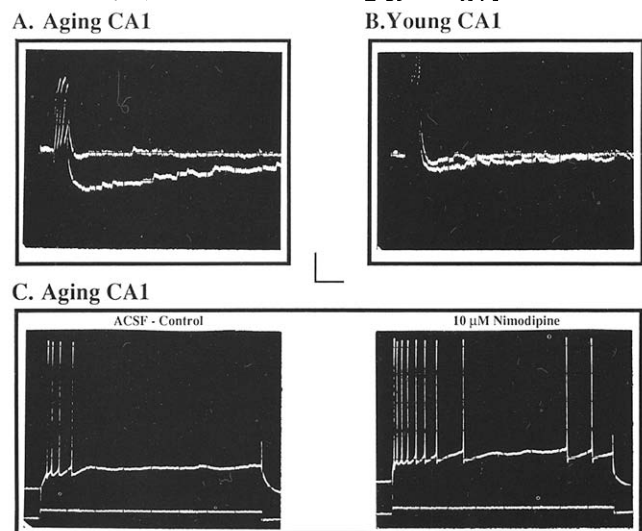

Fig. 3. Nimodipine reduces the afterhyperpolarization and spike accommodation in CA1 neurons in hippocampal slices from young and aging rabbits. A,B: overlay recordings of the afterhyperpolarization following a burst of 4 action potentials (4-spike AHP) before and after 10 μ M nimodipine (bath applied). The AHP was reduced to a greater extent after nimodipine application in the aging than in the young CA1 neuron (RMP = -73 mV). C: accommodation to a prolonged depolarizing pulse was reduced in an aging CA1 neuron following nimodipine application. The same current amplitude used to elicit the 4-spike AHP was used to study accommodation. Calibration: 5 mV, 200 ms (A,B) and 20 mV, 100 ms (C).

than in young animals, which is consistent with the aging-related calcium disturbances discussed earlier. Other calcium channel blockers nifedipine and flunarizine, which alter cerebral blood flow but cross the blood-brain barrier to much lesser degrees, had essentially no effect. These data suggest that nimodipine acts directly

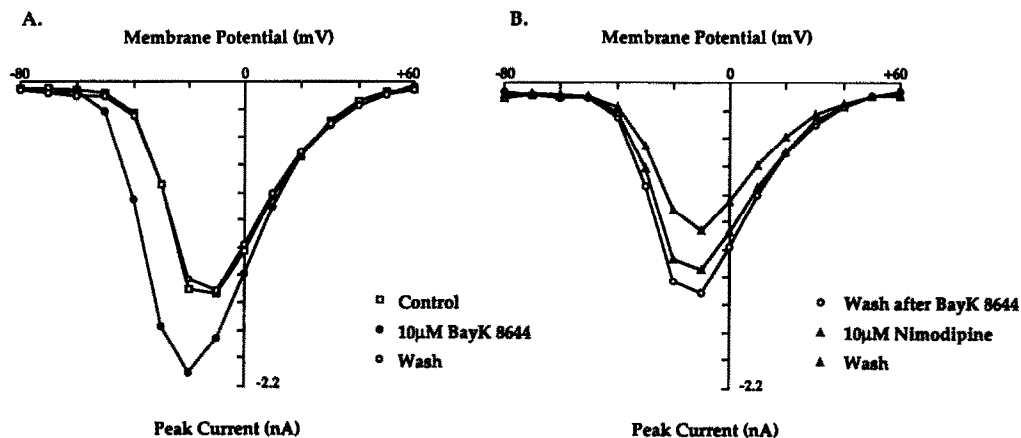

Fig. 4. The effects of 10 μ M BAY K 8644 and nimodipine on the calcium current in the same cell are summarized throughout the voltage range of current activation. First, BAY K 8644 was applied, followed by a wash and then nimodipine was applied and washed. The cells were stepped from a holding potential of -80 mV to potentials up to +60 mV with 10 ms voltage commands. A: bay K 8644 enhanced maximal current amplitude to as much as 140% of control and also shifted both threshold and peak activation voltage in the hyperpolarized direction. B: nimodipine attenuated the current to as much as 70% of control without changing its initial and peak activation. Both effects were reversed after washing.

in vivo, raising the baseline firing activity of CA1 pyramidal neurons, especially in aging animals. This effect is of particular interest, since CA1 pyramidal neurons show firing-rate facilitation during learning as reviewed above.

Next, we addressed the issue of whether nimodipine reduces the calcium-dependent afterhyperpolarization, using bath application of 10 μm nimodipine in the hippocampal slice (Fig. 3, Ref. 106). Nimodipine causes a consistent and large, reduction of the slow AHP recorded intracellularly in CA1 pyramidal neurons. This reduction is evident in slices from young adult rabbits, but is particularly marked in slices from aging hippocampus. The AHP reduction is accompanied by a marked increase in the number of action potentials elicited by a long depolarizing pulse. This reduction in spike accommodation, cellular evidence for enhanced neuronal excitability, and the reduced AHP were not accompanied by alterations in input resistance to hyperpolarizing pulses.

Finally, we examined the possibility that the reduced AHP could be secondary to a reduced calcium influx evoked by the action potential volley used to elicit it. Landfield⁸⁰ has shown that nimodipine reduces the calcium current in aging hippocampal neurons recorded in hippocampal slices. We addressed this issue initially with whole-cell voltage clamp recordings made from acutely dissociated guinea-pig CA1 pyramidal cells (Fig. 4, Ref. 20). Nimodipine (10 μm) is effective in blocking the non-inactivating, high-threshold calcium ('L-type') current to 70% of control in CA1 neurons. Nimodipine did not alter the threshold for activation or inactivation of this current, but did increase its peak permeability. BAY-K-8644, an L-type calcium channel agonist, shifted the voltage-dependence to the hyperpolarized direction, prolonged the tail current and caused a reliable and reversible enhancement of the calcium current to as much as 150% of control. The effects of both dihydro-

pyridines were obvious immediately after application and disappeared rapidly and generally completely after wash. The calcium agonist and antagonist effects obtained in dissociated cells complemented the data obtained earlier in vivo and in brain slices. Nimodipine clearly has a direct action on calcium currents in hippocampal CA1 neurons which is consistent with the behavioral facilitation we have observed.

We have summarized a series of experiments which show that nimodipine, a calcium channel blocker which readily crosses the blood brain barrier to gain access to hippocampal neurons, has the capacity to facilitate hippocampally dependent learning tasks, especially in aging animals. Our experiments in young animals have demonstrated that a striking correlate of learning in the hippocampus is a reduction in calcium-activated potassium currents. We have not yet demonstrated directly that manipulation of these currents in aging animals by nimodipine underlies the learning acceleration we have observed. However, our experiments to this point are consistent with this possibility. Recent evidence that dihydropyridine-sensitive calcium channels of CA1 pyramidal neurons are located on the soma¹⁶¹ is certainly consistent both with our data and with our working hypothesis. Blockade of a large calcium conductance on the soma, near the spike-generating region of the neuron, should have maximal influence on pyramidal cell excitability. Modulation by nimodipine should be especially marked in aging neurons, where calcium-activated potassium conductance are particularly large. Our experimental strategy attempts to apply insights into the cellular mechanisms of associative learning gained in experiments with young animals to the amelioration of learning dysfunctions associated with aging. We are hopeful that our approach may be fruitful both theoretically and clinically.

4. Use of developing visual cortex as a model to study the mechanisms of experience-dependent synaptic plasticity

Mark F. Bear

The striate cortex, area 17, of the cat has proven to be a useful model system for the investigation of the mechanisms of experience-dependent synaptic modification in the cerebral cortex. Work over the last 25 years has shown that simple manipulations of the visual environment during the second two postnatal months lead to lasting changes in the physiology and structure of the visual cortex and, consequently, in behavior. For example,

a brief period of monocular deprivation renders striate cortex unresponsive to stimulation of the deprived eye and renders the animal blind through this eye.

Despite the complexity of the neocortex, considerable progress has been made lately in understanding the mechanisms of visual cortical plasticity. This progress has been due in part to detailed theoretical analysis of the possible rules of cortical self-organization. Theory

suggests that visual cortical plasticity can be understood if mechanisms exist to strengthen synapses whose activity coincides with target depolarization beyond some threshold level and conversely, to weaken synapses whose activity consistently fails to correlate with postsynaptic activation. In addition, mechanisms must exist to constrain synaptic weights so that the network of cortical synapses reaches a stable equilibrium. On this last point, there are significant differences between the various theories.

One theory of synapse modification in visual cortex was presented by Bienenstock, Cooper and Munro¹⁹ (BCM) in 1982. According to BCM, synaptic modifications proceed as the product of input activity and a function (ϕ) of postsynaptic depolarization. At a critical value of postsynaptic activation, called the modification threshold (θ), ϕ changes sign from negative to positive. Thus input activity coincident with postsynaptic activation greater than θ yields a potentiation of activated synapses and input activity coincident with postsynaptic depolarization smaller than θ yields a depression of activated synapses. The feature of this theory that ensures stability is that the value of θ is not fixed, but rather floats as a non-linear function of the recent history of postsynaptic cell activity. Computer simulations have shown that the outcome and kinetics of a wide variety of deprivation experiments in kitten striate cortex can be explained using the BCM theory²⁷.

Recent advances in our understanding of excitatory amino acid (EAA) receptors have suggested a plausible physiological basis of this form of synaptic modification. In 1987, Bear et al. proposed that θ related to the membrane potential at which the NMDA receptor-dependent Ca^{2+} flux reached the threshold for inducing synaptic long-term potentiation (LTP). In support of the hypothesis that NMDA receptor mechanisms play a role in synaptic plasticity, we have found that the pharmacological blockade of NMDA receptors with the competitive antagonist AP5 disrupts the physiological^{16,75} and anatomical¹⁵ consequences of monocular deprivation in striate cortex. Although the interpretation of these experiments is compromised by the finding that AP5 reduces visually evoked responses⁴⁷, the data indicate that activity evoked in visual cortex in the absence of NMDA receptor activation is not sufficient to support binocular competition. Furthermore, work in a number of laboratories has lent strong support to the hypothesis that a lasting consequence of NMDA receptor activation in visual cortex is synaptic potentiation. In fact, Artola et al.¹² have presented data that are in striking agreement with the hypothesis of Bear et al. (1987). They find in slices of rat visual cortex that tetanic stimulation of the optic radiation fibers can yield a long-lasting synaptic depression

(LTD) or LTP depending on whether the postsynaptic membrane potential during the tetanus is depolarized sufficiently to recruit an NMDA receptor conductance.

There are indications, however, that the contingencies required for LTP induction might be more complex in neocortex. Although the balance of available evidence suggests that NMDA receptor activation beyond some critical value can induce LTP, this does not necessarily mean that activation of NMDA receptors is essential for LTP induction in neocortex. We have several examples of LTP induced in the presence of $100 \mu\text{M}$ D,L-AP5, a drug concentration that blocks more than 95% of the NMDA receptors (Press and Bear, unpublished results). A similar AP5-resistant LTP has been reported in the CA1 region of the hippocampus⁶². If these modifications are input specific, then this finding argues for the existence of coincidence-detection mechanisms in addition to the NMDA receptor. This might have important implications for understanding the molecular basis of experience-dependent synaptic plasticity, both in hippocampus and neocortex. The identification of such a mechanism also may permit synaptic plasticity to be dissociated from synaptic transmission in visual cortex in vivo.

The mechanism that underlies LTD is unknown. One possibility is that an elevation of postsynaptic Ca^{2+} below a critical value is the trigger for LTD⁸⁴. We have advanced the alternative hypothesis that LTD might be mediated by the Q_2 receptor, a type of non-NMDA receptor that is linked specifically to phosphoinositide turnover^{17,40}. In support of this proposal, we have found that AP3, a compound that interferes with EAA-stimulated phosphoinositide turnover, disrupts the functional disconnection of the deprived eye that normally occurs in striate cortex after monocular deprivation⁴¹ and it has been reported that AP3 blocks a form of LTD in hippocampus²⁵. However, progress in this area has been hampered by the fact that the extant models of synaptic weakening in cortex have not as yet proven to be very reliable in the hands of others.

Although many of the details remain to be worked out, both for neocortical LTP and LTD, the evidence strongly suggests that the basic structure of the BCM theory has a plausible molecular basis in the visual cortex. A key feature of the theory is the sliding modification threshold (θ). Translated into the NMDA hypothesis of Bear et al. (1987), BCM predicts that the critical value of postsynaptic depolarization at which the NMDA receptor activation leads to LTP induction is not fixed, but rather varies as a function of the recent history of cell activity.

Theory suggests that the value of θ is low after a brief period (4–6 days) of binocular deprivation (BD) in kitten striate cortex. We have begun to explore the possi-

bility that BD alters the effectiveness of visual cortical NMDA receptors. Our data suggest that although the density of [^3H]MK801 binding sites is unaffected by BD¹²³, NMDA stimulated $^{45}\text{Ca}^{2+}$ accumulation is significantly decreased in visual cortical slices prepared from binocularly deprived (but not monocularly deprived) animals⁴⁶. One explanation (among many) for this result is that BD causes a decrease in intracellular Ca^{2+} -binding proteins. This hypothesis is particularly attractive in light of work by Holmes and Levy⁶⁸, suggesting that induction of LTP by NMDA receptor activation might be particularly sensitive to changes in calcium buffers in dendritic spines. Regardless of the mechanism, however, these $^{45}\text{Ca}^{2+}$ uptake experiments indicate that cortical calcium homeostasis varies significantly with activity. More work is required to assess the impact of these changes on visual cortical plasticity.

5. Is there “channelling” of information through the intrinsic circuit of the rat hippocampus?

David G. Amaral

In a recent commentary⁶, we summarized anatomical data concerning the intrinsic organization of the rat hippocampus. We concluded that the anatomy does not support the notion that the hippocampal formation is organized in a lamellar fashion⁸. As originally proposed, the lamellar hypothesis suggested that “a point source of entorhinal activity projects its impulses through the 4-membered pathway (of the hippocampal formation) along a slice or lamella, of hippocampal tissue oriented normally to the alvear surface” and perpendicular to the long axis of the hippocampus. The functional implication of the lamellar notion was that information entering a particular septotemporal level of the hippocampal circuit would not diverge extensively to other septotemporal levels of the hippocampal formation. However, a number of neuroanatomical studies, including our own recent work with the lectin anterograde tracer *Phaseolus vulgaris* leucoagglutinin (PHA-L), have demonstrated that the associational connections, particularly of the dentate gyrus and the CA3 field of the hippocampus, are as extensive in the septotemporal axis as they are in the transverse axis⁶⁴. Projections between hippocampal fields, from CA3 to CA1 for example, are also massively divergent along the septotemporal axis. The implication of this anatomical organization is that there is substantial dispersion of information entering at any particular septotemporal level along much of the long axis of the hippocampal formation.

In summary, the interaction of theory and experiment allows us to identify 3 avenues of research that should influence our understanding of experience-dependent synaptic modification and, consequently, of the mechanisms of learning and memory storage. First, there should be a critical reexamination of the hypothesis that NMDA receptors are the only coincidence detectors needed to account for LTP in the cerebral cortex. Second, a reliable model of LTD needs to be established and exploited to uncover the molecular basis of use-dependent synaptic weakening. Third, more work is required to establish that the modifiability of cortical synapses is a function of activity and, if so, to identify the underlying mechanism. I think that it is safe to say that we can look forward to considerable progress in these areas in the years to come.

While many of the intrinsic connections have a substantial septotemporal divergence, it has become equally clear that not all neurons at a particular septotemporal level of an innervated field receive an equal density of innervation. In other words, it is not the case (as often illustrated in simplified schematic diagrams of hippocampal circuitry) that a CA3 neuron at a particular septotemporal level contacts cells throughout the transverse extent of the CA1 field at the same level. As described below, the region of CA1 that will be innervated by a particular CA3 cell appears to be dependent on the transverse position of the cell of origin in the CA3 field. There is increasing evidence, therefore, for a subregion to subregion (or transverse) topography of intrinsic hippocampal connectivity and thus the anatomy suggests that information may be “channelled” through the fields of the hippocampal formation. In the following paragraphs, I will briefly outline the general pattern of certain of the intrinsic connections of the hippocampal formation and indicate how the anatomy provides the basis for potential regional segregation of information processing.

Mossy fibers, arising from the dentate granule cells, constitute the only hippocampal fiber system that projects in a lamellar fashion²⁶. Since each mossy fiber projects throughout the CA3 field and has approximately 14 en passant synapses separated one from the next by approximately 140 μm , it is likely that selected CA3 pyramidal

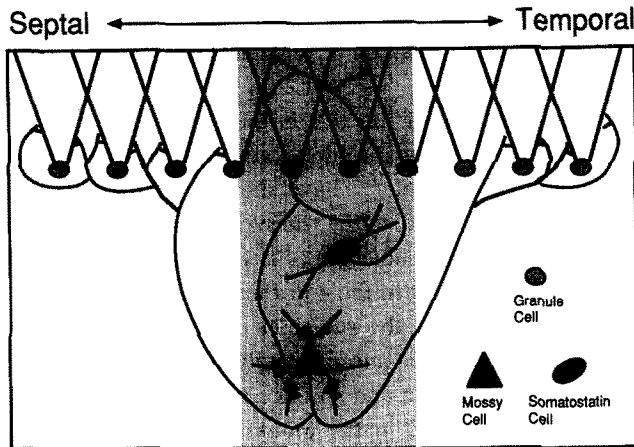

Fig. 5. Schematic illustration depicting some of the intrinsic connections of the dentate gyrus. Granule cells give rise to mossy fibers which collateralize in the polymorphic layer and terminate on mossy cells and somatostatin immunoreactive cells. The somatostatin immunoreactive cells give rise to projections that terminate in the outer half of the molecular layer at the same septotemporal level (gray region) as the cells of origin. The mossy cells, in contrast, contribute to the classical associational projection that terminates in the deep third of the molecular layer. PHA-L anterograde mapping studies indicate that the mossy cells do not project to their own septotemporal level. Rather, mossy cells give rise to axons that travel for approximately 1 mm from the cells of origin before contributing a plexus of terminal fibers in the molecular layer. Thus, the associational projection appears to be organized to distribute information from one septotemporal level of the dentate gyrus to other distant levels.

cells in all transverse parts of the field are potentially innervated by each granule cell.

While connections of the dentate gyrus do not demonstrate any apparent transverse organization, one of the most striking examples of divergence in the hippocampal formation is found in the associational projection of the dentate gyrus (Fig. 5). Cells located in the hilus of the dentate gyrus (the polymorphic layer) are innervated by collaterals of the mossy fiber axons¹²⁴ and, in turn, send projections to the molecular layer of the dentate gyrus. We have recently observed that the associational projection is heterogeneous in its origin and distribution. A population of somatostatin immunoreactive neurons gives rise to a projection that terminates in the outer two-thirds of the molecular layer. This projection is confined to the region within approximately 1–2 mm of the cells of origin. The more classical associational projection originates from larger “mossy cells”. Interestingly, our PHA-L studies⁶, (Amaral, unpublished observations) have demonstrated that mossy cells do not project to the level of the dentate gyrus at which they are located (and from which they receive their input from the granule cells) but rather give rise to axons that travel approximately 1 mm septally or temporally before contributing a terminal plexus within the inner third of

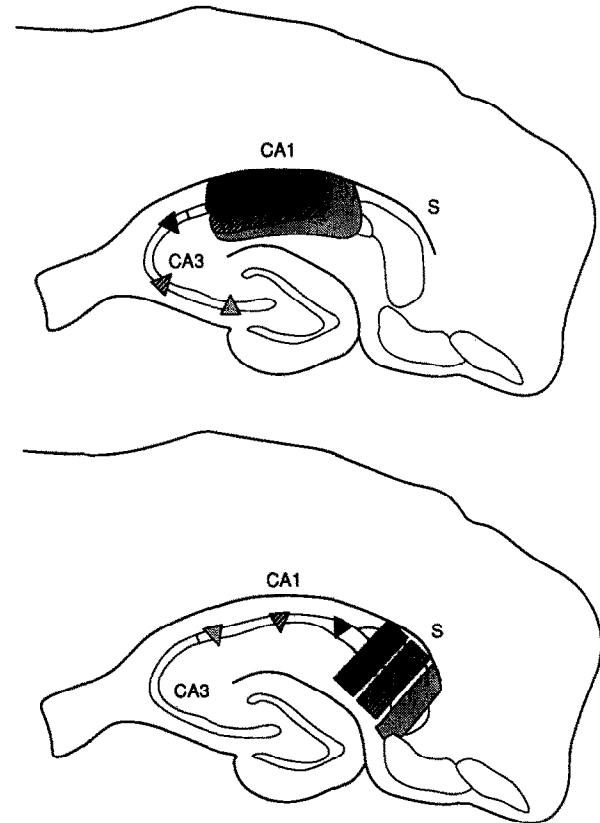

Fig. 6. Top: line drawing of a horizontal section through the rat hippocampal formation, indicating the organization of CA3 projections to CA1. The areas of heaviest labeling in CA1 arising from different transverse regions of the CA3 field are indicated by the shading patterns in the triangles in CA3 and the terminal fields in CA1. Bottom: line drawing of a horizontal section through the rat hippocampal formation indicating the organization of CA1 projections to the subiculum. Different transverse portions of the CA1 field (indicated by triangles) give rise to columns of terminal ramifications in the portions of the subiculum indicated with the same shading patterns.

the molecular layer (Fig. 5). Thus, the associational projection of the dentate gyrus does not appear to be organized for feedback of information but rather to convey information from one level of the dentate gyrus to other distant septotemporal levels.

Indications of a transverse organization of hippocampal projections begin to appear in the CA3 projection to CA1. As illustrated in Fig. 6 (top), CA3 cells located close to the dentate gyrus tend to project most heavily to CA1 cells located near the CA1/subicular border. CA3 cells located nearer to CA2, in contrast, project most heavily to the CA1 cells located close to CA2 (Ref. 71). Projections from any particular septotemporal level of CA3 diverge to involve much of the septotemporal extent of the CA1 field⁷¹. As one proceeds septally or temporally from the injection site, the region of heaviest termination shifts within the CA1 field (Fig. 7). The transverse and radial gradients of CA3 terminal distri-

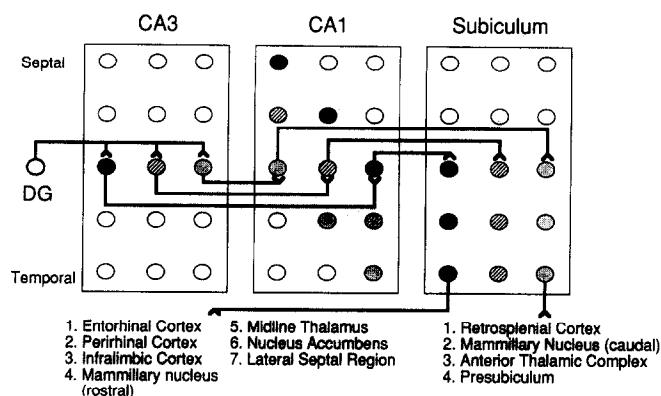

Fig. 7. Highly simplified illustration of intrinsic connections of the hippocampal formation. Granule cells generate mossy fiber axons that terminate throughout the transverse extent of the CA3 field, CA3 cells located proximally in the field (black filled circle located close to the dentate gyrus) project to distal portions of the CA1 field. CA3 cells in the distal part of the field, in contrast, project just across the CA2/CA1 border into the proximal part of CA1. The projection from CA3 to CA1 diverges in the septotemporal direction and the region of highest terminal density shifts proximally as one proceeds septally and shifts distally as one proceeds temporally (see position of circles with similar shading patterns). The CA1 projection to the subiculum terminates in a columnar fashion. Proximal CA1 cells give rise to projections that terminate in a columnar fashion in the distal part of the subiculum (close to the presubiculum) whereas distally positioned CA1 cells project just across the CA1/subiculum border into proximal subiculum. The "channeling" of information through CA3, CA1 and subiculum is indicated by the circles in each field which are labeled with the same shading pattern. As Witter et al.¹⁶⁴ have demonstrated, the various extrinsic outputs of the subiculum arise from cells in different transverse regions within the field. Subicular efferent data are from Ref. 164.

bution in the CA1 field are described fully in Ishizuka et al.⁷¹ and will not be considered further here.

The CA1 projection to the subiculum demonstrates the clearest transverse pattern of organization¹⁵⁰ (Fig. 6, bottom). The CA1 cells located nearest CA2 project in a columnar fashion onto the subicular pyramidal cells located closest to the presubiculum, whereas the CA1 cells located near the subiculum project to the subicular pyramidal cells located just across the CA1/subiculum border. While the CA1 to subiculum projection shows substantial septotemporal divergence, unlike the CA3-

to-CA1 projection, there does not appear to be any shift in the transverse position of termination at different septotemporal levels.

The subiculum of the rats is the major source of efferent projections of the hippocampal formation. Interestingly, Witter et al.¹⁶⁴, have shown that there is substantial heterogeneity in the transverse origin of subicular efferents (Fig. 7). Subicular cells located close to CA1, for example, project to the entorhinal cortex and nucleus accumbens whereas the subicular cells located near the presubiculum project more heavily to the retrosplenial cortex, presubiculum and anterior thalamic complex. We have recently found in the monkey, as Steward¹⁴⁶ had previously demonstrated in the rat, that the entorhinal cortex projection into the subiculum and CA1 is also organized in a transverse fashion. Rostral levels of the monkey entorhinal cortex (equivalent to the lateral entorhinal cortex in the rat) project to the border of the CA1 with the subiculum whereas progressively more caudal levels of the entorhinal cortex (equivalent to the medial entorhinal cortex of the rat) project to more distal regions of the subiculum and more proximal regions of CA1. Similarly, the projection from the perirhinal cortex terminates exclusively along the CA1/subiculum border¹⁴⁹; no other transverse portions of the CA1 field receive an input from the perirhinal cortex.

These data suggest that cells located within different transverse portions of CA1, the subiculum and perhaps other hippocampal fields are influenced by different sources of input and give rise to distinct intrinsic and extrinsic outputs. This raises the functional possibility that partitions of each hippocampal field selectively channel information to the next field of the intrinsic circuit and ultimately the information is parceled out to different efferent regions of the hippocampal formation. One functional implication of this scenario is that physiological response characteristics of cells in, for example, different transverse positions of a particular septotemporal level of the CA1 field might be quite distinct. Moreover, the response properties of cells should be more similar in the unlinked transverse regions of connected fields than in the regions.

6. Associative pattern completion in hippocampal circuits: new evidence and new questions

Bruce L. McNaughton

Recent behavioral evidence supports the general hypothesis that the hippocampal formation is capable of at least temporary storage of information in an associative

manner¹⁷⁴. In addition there is general agreement that at least one mechanism for synaptic modification (LTE/LTP) exists in this structure, with something like the req-

uisite cooperative (i.e., 'associative') properties; however, neither is there general agreement as to how this synaptic weight change may implement associative memory within the hippocampal circuitry and its affiliated cortical structures nor has there been any direct evidence that the hippocampal circuits themselves are capable of reconstructing stored representation from fragmentary input. The latter capability is the defining characteristic of an associative memory system.

Perhaps the first convincing evidence that stored representations could actually be recalled either into or within hippocampal circuits was provided by O'Keefe and Speakman¹¹¹. They showed that, in a cue-controlled environment, spatially selective firing of hippocampal cells persisted after the removal of the controlled cues, provided the removal was carried out in the rat's presence. Accurate spatial discharge persisted so long as the animals could show behaviorally that they knew where they were in relation to the most recently presented orientation of the cue array. This general conclusion, that spatial representations can be recalled from memory into hippocampal circuits, was confirmed and extended by McNaughton, Leonard and Chen^{96a} and by Quirk, Muller and Kubie¹²⁰. The remaining question is whether the associative recall operation itself can occur within the hippocampus, or whether the recalled information must be conveyed from other structures. Such a demonstration requires both knowledge and some control of the input to the network as well as the ability to quantify the information content of its output.

Marr⁹⁴ suggested that associative pattern completion might occur in the hippocampus through a combination of 'Hebbian' synaptic enhancement (during storage) and a 'normalization' operation during recall such that the recall cells could increase their excitability according to how much of the previously stored pattern was missing. To do this, the network needed to be informed about how many inputs were currently active and then to divide the excitation of the recall cells by an amount proportional to this activity. In this way, only those output cells would reach a threshold for which all or most of the currently active inputs possessed enhanced connections. Marr suggested that this normalization operation could be performed by feed-forward inhibitory cells, which would sample the input and feed-forward the appropriate division signal. A discussion of this theory in the light of more modern data on hippocampal anatomy, physiology and information processing can be found in McNaughton and Nadel⁹⁸.

Recently, in the course of the experiments addressing a different issue, evidence was obtained that seems to support the Marr's input normalization theory. Mizumori et al.¹⁰² examined the effects of temporary inacti-

vation of the medial septal nucleus (with a microinfusion of local anaesthetic) on spatial working memory and single unit discharge rates and their spatial selectivity in the hippocampus of behaving rats. We observed a dramatic reduction in both discharge rates and spatial selectivity in pyramidal cells of hippocampal field CA3, as well as a severe impairment on the spatial working memory task, lasting for the 15–20 min drug effect. In spite of the substantial reduction in the quantity and quality of information they received from CA3, the main source of afferents to CA1, there was no significant effect on either mean discharge rate or spatial selectivity in pyramidal cells of field CA1. As predicted by Marr's normalization theory, however, inhibitory cells in CA1 underwent a substantial reduction in their discharge rates, approximately as great as the reduction of CA3 firing.

It seems that there are at least two possible interpretations of these data. The one just presented relies on the notion that CA1 acts as a kind of linear autoassociative network^{96,97}. The slightly different possibility is that the fundamental source of spatial information to CA1 derives from the entorhinal cortex via its direct afferents which arise primarily in layer III rather than via the classical 'trisynaptic' loop. In this view, CA1 would act in the manner of an 'heteroassociator'^{9,76,97,163} in which the direct inputs act as the sparse, 'forcing' stimulus, and the Schaffer collaterals provide the modifiable connections. Evidence for direct activation of CA1 pyramidal cells has recently been presented¹⁷¹. Under this view, the CA3 inputs would not be required for CA1 output so long as the spatial information conveyed from the environment via the direct pathway was intact.

A second issue related to the foregoing experiments is why, if the CA1 output is intact, is spatial memory so severely impaired? Clearly a number of possibilities exist, not the least of which is that local inactivation of the septum and fibers of passage may block spatial working memory, via an affect on other neocortical structures. Given the known projections of the medial septum on the subicular complex and entorhinal cortex, the main hippocampal *output* structures, it seemed reasonable to examine the hypothesis that spatial memory might be disrupted, in spite of normal activity in CA1, because this activity was prevented from propagating beyond CA1 back to the rest of the cortex. We have conducted preliminary experiments in anaesthetized animals¹¹⁹ in which neural activity was monitored simultaneously in CA3, CA1, subiculum and entorhinal cortex during local inactivation of the medial septum as just described. There was, indeed, a severe depression of activity in both the subiculum and entorhinal cortex, with only mild effects in the hippocampus proper. These results provide

a tentative explanation for the memory impairment as well as supporting the former conclusion that CA1 is capable of reconstructing complete spatial representations

from fragmentary input provided over its Schaffer collateral inputs.

7. Possible contributions of long-term potentiation to the encoding and organization of memory

Gary Lynch and Ursula Staubli

7.1. Introduction

Any attempt to identify the substrates of memory faces the problem of defining memory. It is widely held that multiple memory systems exist¹³⁵ but there is nothing like a consensus on whether the number of such systems is large or small or even what characteristics should be used to define particular categories. LTP has a number of features that are suggestive of the type of memory which it might subserve. The potentiation effect is synapse specific and develops⁶³ and stabilizes¹¹ within 1–2 min. These properties would be needed by an encoding system that dealt with a very large amount of material perhaps occurring as a steady stream of input. The NMDA receptor is concentrated in the telencephalon¹⁰³ as are the subunits of the AMPA receptor^{52,67}. It is also the case that the physiological rhythms ideally suited for inducing LTP are found throughout the olfactory hippocampal system^{43,49,77} and also occur in neocortex^{50,61}. The human brain is characterized by an enormous expansion of the telencephalon (greater than 90% of the brain by volume is neocortex) and rapid, stable encoding of vast amounts of material¹³⁹ is certainly a hallmark of human memory. It is not unreasonable then to begin with the assumption that the form of memory subserved by LTP is commonplace to human experience. But human memory is also selective in that some material is encoded in a stable fashion while memory for other items gradually decays. It would seem that the importance of information to the observer influences the stability of the encoded representation, an idea that implies that memory structures in brain interact with the storage process or that different sites of encoding have different stabilities.

The above arguments and questions have influenced our attempts to investigate the potential contributions of LTP to memory and specifically have led us to focus on the circuit running from the olfactory bulb through hippocampus. The olfactory system is contained within the telencephalon to a much greater degree than is the case for the other sensory modalities in non-primate, laboratory animals. We assume therefore that much of olfactory memory involves pathways capable of exhibiting

LTP. The olfactory cortex is somewhat simpler than neocortex and this is a decided advantage in experimental studies. Olfaction also connects to human memory-related structures such as hippocampus and frontal cortex via well-defined circuits containing 2 or 3 links, something which is not the case for other sensory systems. This makes it feasible to study LTP in sequential structures and hence ask questions about relative stability. Finally, behavioral studies show that rats are able to learn very large numbers of odors with a minimal number of training trials on each odor and that the encoded memories are extremely stable¹⁴². Moreover, there is evidence that the memories are organized into clusters that the animals use in dealing with new cues⁵⁹, a feature that resembles a salient property of human memory. In the following sections, we will briefly review some of the results obtained in our studies on LTP and olfactory memory.

7.2. Inhibitors of long-term potentiation interfere with rapid learning of new odor cues

In one group of studies, rats were trained in a series of two odor discriminations until they were able to acquire new discriminations in 5–10 trials. Behavioral studies have shown that the animals learn both odors (i.e., positive and negative cues) and as noted that the resultant memories last for months¹⁴². Infusions of the NMDA receptor antagonist AP5, a drug known to block LTP, interfered with learning in the first 10 trials provided that weak concentrations of odors were used; stable memories were formed if additional trials were given. Performance using odors learned *before* drug administration was normal in the experimental animals¹⁴⁵. These effects of AP5 resemble those obtained with denervation of the hippocampus^{142a}. Early work established that discrimination learning is also blocked by a drug that blocks calpain (a calcium-activated protease) at concentrations that also prevent the stabilization of LTP¹⁴⁴. Neither the enzyme inhibitor nor AP5 prevented shock avoidance learning; conversely, a protein synthesis inhibitor was found to block avoidance conditioning but not odor learning¹⁴¹.

7.3. Long-term potentiation in the different stages of the olfactory-hippocampal circuit

Theta burst stimulation of the lateral olfactory tract connections between olfactory bulb and layer Ia of piriform cortex did not induce LTP, a result which accords with previous observations^{121,148}. LTP did occur when the stimulation was used as a discriminative cue in place of a real odor in the above-mentioned two-odor task¹²⁵. Thus, LTP in the second stage of the olfactory-hippocampal circuit (counting the olfactory nerve to mitral cells as stage one and mitral cells to cortex as stage two) is behaviorally dependent. How this behavioral influence is achieved is now under investigation but a likely possibility is the cholinergic input from the horizontal link of the diagonal bands¹⁶⁷. Subsequent work on slices of piriform cortex revealed that LTP can be induced in the LOT connections when conditions are used that facilitate the opening of the NMDA receptor ionophores; interestingly, the associational projections which interconnect the subdivisions of olfactory cortex and which terminate on the same dendrites as the LOT synapses do not have special requirements for LTP induction⁷².

The connections between the caudal extension of the olfactory cortex (i.e., lateral entorhinal cortex) and the dentate gyrus constitute the 3rd stage of the olfactory-hippocampal circuit. (The lesser connections between cortex and the pyramidal cell fields will not be considered here). McNaughton et al.⁹⁹ have reported that LTP in these synapses is a decremental effect, with a duration of about 2 weeks. This stands in marked contrast to the stable potentiation found in other stages of the circuit^{125,140}. The mossy fibers between the granule cells of dentate gyrus and pyramidal cells of field CA3 form the 4th link in the sequence of connections. We have recently obtained evidence that the potentiation produced by high frequency stimulation of the mossy fibers is not LTP. Specifically, mossy fiber potentiation (MFP) greatly reduces paired-pulse facilitation ratios, strongly suggesting that MFP is a presynaptic phenomenon^{143,173}. LTP in the dentate gyrus¹⁰⁰ and field CA1 does not affect paired-pulse facilitation or any of several other manipulations known to increase release¹⁰⁸. MFP lasts for several hours in slices but there are good reasons to assume that the effect is transient (see Ref. 86 for a discussion). The discovery that hippocampus contains two qualitatively distinct forms of potentiation provides a useful clue as to the types of memory operations that it performs.

The 5th stage of the olfactory-hippocampal circuit involves the Schaffer-commissural projections from field CA1. LTP in these synapses does not appear to be behaviorally dependent and once induced can persist without decrement for weeks¹⁴⁰ (the longest time period over

which recordings could be made in chronic animals).

7.4. Mnemonic phenomena in computer simulations of olfactory networks using long-term potentiation-based learning rules

The above sections indicate that variants of LTP are present in 3 stages of the olfactory-hippocampal circuit and that the potentiation effect is likely to play a role in memory. Computer modelling provides a means for asking what properties might emerge from a memory system based on LTP. Studies of this kind first require definition of the spatiotemporal patterns of activity leading to the potentiation effect, i.e., the description of LTP-based 'learning rules' for the network models. The olfactory system in small mammals operates at a rhythm of 4–7 Hz known as theta (θ). This is the rate at which odors are sampled (see Ref. 172 for an elegant demonstration) and it has been known for some time that sniffing synchronizes activity throughout the olfactory-hippocampal circuit⁷⁷. Superimposed on θ is a much faster rhythm in olfactory bulb and cortex^{49,50} and cells in hippocampus fire in short, high-frequency bursts at the peaks of the θ waves⁴³. Experimental work in slices has shown a remarkable correspondence between these parameters and the optimal stimulation conditions for inducing LTP. Thus, 30-ms long bursts of high-frequency activity induce LTP when the bursts are separated by the period of the θ rhythm (approximately 200 ms) and are progressively less effective in this regard when given at shorter or longer intervals⁸¹. The reasons for the peculiar efficacy of this ' θ burst pattern' have been identified⁸². The correspondence between naturally occurring activity patterns and optimal conditions for LTP induction provides further evidence that the potentiation effect is relevant to behavior.

Additional studies using the θ burst paradigm have led to a set of rules describing the degree of LTP which emerges when afferents arrive at a common target cell in various temporal configurations⁸³; see Ref. 88 for a review). These rules were then implemented in a neural network model of the olfactory cortex and olfactory bulb^{7,87}. These networks exhibit a number of interesting and in some cases surprising behaviors. After learning dozens of simulated 'odors', they are able to dissect composites into their constituents. More directly related to the present discussion, they organize memories into similarity based hierarchical clusters such that sequential sampling ('sniffs') generates successive spatial patterns of activity that denote the group and then subgroup to which the cue belongs; after several samples, a pattern emerges which is specific to the odor now present⁷. It should be noted that this behavior emerges from the combination of LTP rules and anatomical architectures

used in designing the network rather than as an explicitly designed feature. As mentioned, behavioral studies have now shown that rats do form hierarchical organizations for odors⁵⁹.

7.5. Summary and discussion

Three lines of experimental evidence linking LTP to olfactory memory were described above: (i) drugs which block the potentiation effect disrupt the acquisition of odor discriminations^{141,145}; (ii) LTP develops in LOT synapses when electrical stimulation is used as a discriminative cue¹²⁵; and (iii) activity patterns present during learning are optimal for inducing LTP^{81,82}. Studies on 4 of the links of the olfactory-hippocampal circuit uncovered significant variations in LTP as well as a type of long-lasting synaptic facilitation that is distinct from LTP. These observations suggest the hypothesis that properties are added to memory in a sequential fashion as information moves along the successive steps of cortico-hippocampal connections. The following suggestions constitute one of several possible scenarios concerning what these properties might be: (i) *stage 2* (LOT-piriform); behavioral dependence of LTP¹²⁵ allows attentional mechanisms to select information to be learned;

(ii) *stage 3* (cortex-dentate gyrus); decremental LTP⁹⁹ serves as a device for measuring how much time has passed since the last encounter with a cue; this could also provide a kind of transient encoding that occurs prior to more stable storage; (iii) *stage 4* (dentate gyrus-field CA3); a 'daily' memory of cues encountered and acted upon in the immediate past; this idea arises from the observations that granule cell activity is movement dependent^{32,126} and the argument, still untested, that mossy fiber potentiation is transient⁸⁶; and (iv) *stage 5* (CA3 to CA1): learned temporal sequences of cue occurrences; i.e., that cue 1 is followed by cue 2 (Refs. 43,89,86) and references therein).

More detailed hypotheses of what each of the serial stages of the circuit might add to memory can be obtained using computer simulations incorporating LTP rules and pertinent anatomical architectures as network designs. Some results were described for the bulbar-cortical networks, which suggest that LTP gives rise to a hierarchical organization of memory. This implies that LTP not only serves to encode memory but also functions to arrange it into a particular pattern that should be of considerable utility in evaluating new information.

8. Behaviorally induced changes in the hippocampus

David S. Olton, Stephanie Golski, Mortimer Mishkin, Linda K. Gorman, James L. Olds and Daniel L. Alkon

8.1. Introduction

Measurement of the behaviorally induced changes in the hippocampus can provide important clues about its function. Of particular concern here is the function of the hippocampus in specific associative processes. Because any task that includes an associative process also includes many different non-associative ones, and sometimes several different associative ones, dissociations of behaviorally induced hippocampal neural activity are critical to a functional analysis.

The present experiment used an experimental strategy similar to that developed in the context of classical conditioning, presenting identical stimuli in two different discriminations and varying only the associations among the stimuli. The experiment used variations of the discrimination procedures developed in the Morris water maze¹⁰⁵ and conducted these in an environment with explicit, controlled stimuli. Two different measures of behaviorally induced hippocampal neural activity were obtained, membrane-associated protein kinase C (mPKC) and high affinity choline uptake (HACU). Changes in

mPKC have been produced by the associative processes of classical conditioning in both invertebrates and vertebrates^{1,3}. Changes in HACU have been produced by a variety of spatial mnemonic processes in rats and mice^{33,114,116,117,153}.

8.2. Protein kinase C and memory: a brief review

A role of PKC in the neuronal modifications that underlie mnemonic processes was first demonstrated in experiments with the marine snail, *Hemissenda crassicornis*. *Hemissenda* can be classically conditioned to associate light with rotation, leading to the development of a new conditioned response, shortening of the foot. This conditioned response is encoded by persistent decreases of voltage-dependent K⁺ currents within the B photoreceptor, which lies at a strategic convergence point between the visual and vestibular pathways. Injection of PKC directly into the B photoreceptor with calcium loading produced by light acting on voltage-dependent calcium channels, caused the same changes in the K⁺ current as those produced by classical conditioning⁴. In

both cases, an early K^+ current, I_A and a slower calcium-dependent K^+ current, I_C , had decreased conductance^{2,5}.

The involvement of PKC in classical conditioning in *Hermisenda* was recently confirmed autoradiographically. Pavlovian conditioning increased mPKC as assessed by computerized image analysis within these same B photoreceptors that had biophysical changes produced by learning. This change was behaviorally specific, in conditioned *Hermisenda* but not in controls, and anatomically specific at the cellular level, in neurons crucial to the development of the conditioned response.

In the CA1 hippocampal cell field, 3 days of Pavlovian conditioning of the nictitating membrane in rabbits translocated PKC activity to the membrane¹³. This sustained increase was present 24 h after the last training trial. As with *Hermisenda*, this conditioning procedure, but not the control procedures, decreased the voltage dependent K^+ current in CA1 pyramidal cells^{31,38,85,128}. PKC-activating phorbol esters can mimic the effects of Pavlovian conditioning on this potassium current¹²⁸. All these data suggest an important role for PKC in associative memory storage within the hippocampus.

Computerized image analysis and quantitative autoradiography identified the location of these changes in this enzyme after associative conditioning^{168,169}. In rabbits that had received 3 days of Pavlovian conditioning, mPKC was measured by [³H]PDBU quantitative autoradiography. In the CA1 region of the hippocampus, mPKC was increased in conditioned rabbits but not in controls. This change in the distribution of the enzyme within the hippocampus was long-lasting and dynamic. Whereas the increase was primarily localized in the pyramidal cell somata 24 h after conditioning, it shifted to the basilar dendrites 72 h after conditioning¹¹².

In both the photoreceptor neurons of the snail and the CA1 pyramidal cells of the rabbit, protein targets for PKC changed phosphorylation as a result of the conditioning procedure. One of these targets, a 20,000 M_r G-protein, may have a physiologic homology with the Ras protein.

PKC has been associated with other types of learning. Hippocampal PKC activity was positively correlated with the ability to learn a spatial discrimination in a water maze^{158,159}. Feeding rats *cis*-fatty acids improved performance in a maze and increased PKC-dependent phosphorylation of the PKC substrate B50 (also called CAP43 or Fl) in the hippocampus¹⁶⁵.

Patients with Alzheimer's Disease (AD) had decreased PKC as measured by the binding of radioactive phorbol ester³⁰ and quantitative immunohistochemistry⁹⁵. This decrease does not reflect cell death because fibroblasts from AD patients also had significantly reduced PKC⁷⁰

and it may be specific to the β II isozyme of PKC in the hippocampus and cortex⁹⁵. Thus, the amount of a specific isozyme of PKC is significantly decreased in a human disorder that not only involves memory, but also neuropathology in the hippocampus⁷³.

8.3. Acetylcholine and memory: a brief review

The relation between cholinergic function and memory has a long history and a wide variety of supporting data. Disruption of cholinergic function as a result of neuropathology, drugs, and lesions produced by neurotoxins all have a profound effect on mnemonic function. Some interventions to enhance cholinergic function in mnemonically impaired individuals have been successful, suggesting that cholinomimetic therapy might be an effective cognitive enhancer (see Ref. 14 for a review).

In the context of a specific cognitive ability, such as memory, the most productive statement of 'the cholinergic hypothesis' is one that is restricted to the neural systems involved in memory. Acetylcholine is present in many areas of the brain, and only a few of these are likely to have a direct role in mnemonic processing. The cholinergic system in the medial septal area (MSA) and the hippocampus (H) has been linked most closely to mnemonic functions and is the focus of the subsequent discussion.

Destruction of the cholinergic cells in the MSA by the neurotoxin ibotenic acid impaired choice accuracy in experimental procedures that require recent memory. These lesions reduced the activity of choline acetyltransferase, a marker of cholinergic function, by approximately 50%, reflecting destruction of many, but not all, of the cholinergic cells in the MSA. Recent memory, as assessed by a variety of experimental procedures, was impaired following these lesions. For example, recent memory was assessed by a discrete trial alternation in a T-maze. For each choice trial, the correct response was to enter the arm not entered during the previous forced trial. MSA lesions impaired choice accuracy in this task. Similar impairments followed lesions of another portion of the basal forebrain cholinergic system, the nucleus basalis magnocellularis. (For reviews, see Refs. 113,116, 117.)

Individual differences in the mnemonic competence of aged rats are strongly associated with the integrity of the hippocampal system. Behavioral tests have included recent memory on a radial arm maze and place discrimination in a Morris water maze. Age-related changes in hippocampal physiology, anatomy and metabolic function were correlated with performance in these tasks; the smaller the age-related changes, the better the performance. Of special interest to the present discussion was a strong correlation between age-related changes in cells

of the basal forebrain cholinergic system and performance in the water maze (see for a review Ref. 116).

Manipulation of cholinergic activity in the hippocampus by means of intraseptal microinfusion of substances that act on the cholinergic neurons in the medial septal area (MSA) can have a substantial influence on behavior. The cholinergic cells in the MSA have both cholinergic and GABAergic receptors on them. Stimulation of the cholinergic receptors depolarizes the neuronal membrane, increasing the number of action potentials in the axon and the amount of acetylcholine (ACh) released in the hippocampus. Stimulation of the GABAergic receptors hyperpolarizes the neuronal membrane, decreasing the number of action potentials in the axon and decreasing the amount of ACh released in the hippocampus. Consequently, intraseptal microinfusion of a cholinergic antagonist (scopolamine) and a GABAergic agonist (muscimol) can both decrease cholinergic activity in the hippocampus. In 4-month old rats, both of these compounds reduced the power of the hippocampal θ rhythm and impaired choice accuracy in recent memory tasks. In 24-month-old rats, which have less power in the θ rhythm and reduced choice accuracy in a recent memory task, intraseptal microinfusion of a cholinergic agonist (oxotremorine) partially reduced these age-related electrophysiological and behavioral impairments^{53,114}.

Changes in hippocampal HACU have been produced by experience in several different tasks and some kind of change is usually produced by performance in spatial discriminations such as the one used here. Tests of recent memory in a radial arm maze and in a T-maze increased HACU, and tests of spatial discrimination in a water maze decreased it. Whether these changes are induced by the mnemonic requirements of the tasks remains to be determined. HACU may be altered by many different types of experience^{33,153,160}.

8.4. Protein kinase C, high-affinity choline uptake and spatial memory

The first experiment measured behaviorally induced changes in mPKC and the effects of hippocampal lesions in a two-choice discrimination procedure with two visible platforms in the tank¹¹². The stable platform supported the weight of the rat, allowed escape from water and was the correct choice. The unstable platform did not support the weight of the rat, prevented escape from the water and was the incorrect choice. Each platform had a distinctive visual cue on it, the platform stimulus. A black curtain surrounded the tank. Inside the curtain, tank stimuli were located around the edge of the tank.

One of two discriminations was given to each rat. Both discriminations had the identical stimuli and had only two differences: (1) the topological relation among

the tank stimuli and (2) the topological relation between the tank stimuli and the stable platform, which determined the discriminative stimulus that predicted the location of the stable platform (Table I).

In both discriminations, normal rats learned rapidly, hippocampal lesions produced a substantial impairment, and mPKC in the CA3 region of the dorsal hippocampus was significantly lower than that in cage controls and in rats that swam for an equal amount of time but did not learn a discrimination. The impairment produced by the hippocampal lesion indicates that some hippocampal process was importantly involved in the acquisition of these discriminations. The combined results from the lesions and the changes in mPKC suggest that hippocampal PKC may have a crucial role in this form of learning.

Although the analysis of hippocampal function from lesions and measurement of mPKC was consistent, the impairment in the cued discrimination task was unexpected because most theories of hippocampal function predict normal performance in this task. Consequently, the experimental procedure was changed to produce two discriminations that still had the same stimuli in them, differed only in the associative process necessary to solve the discrimination, but produced the expected dissociation following hippocampal lesions, an impairment in the spatial discrimination, but not in the cued discrimination⁵⁶. Only a single platform was located in the water maze and the top of the platform was below the surface of the water, invisible to the rat. Curtain stimuli, large black and white abstract drawings, were arranged around the tank. A single cue was suspended from the ceiling so that it was 20 cm above the surface of the water. As before, the two groups differed in only two respects: the topological relation among the curtain stimuli and the relevant discriminative stimuli predicting the location of the submerged platform. In the spatial discrimination, the curtain stimuli maintained a constant topological relation and were the discriminative stimuli predicting the location of the platform, which changed its location from trial to trial. In the cued discrimination, the curtain stim-

TABLE I

Summary of experimental design

Type of discrimination	Topological relations		Discriminative stimuli	
	Among tank stimuli	Between tank stimuli and stable platform	Tank	Platform
Spatial	constant	constant	relevant	irrelevant
Cued	variable	variable	irrelevant	relevant

uli changed their topological relation from trial to trial, and the cue was the relevant discriminative stimulus predicting the location of the platform.

Normal rats learned both discriminations quickly. Hippocampal lesions produced the expected dissociation, an impairment in the spatial discrimination but not in the cued discrimination. mPKC is currently being analyzed. The impairment produced by hippocampal lesions in the spatial discrimination is consistent with the results of many previous experiments examining place discrimination in an environment without controlled discriminative stimuli^{104,105}. The predictions for mPKC are obvious. If hippocampal PKC is selectively involved in spatial performance, then it should be altered by experience in the spatial discrimination but not in the cued discrimination.

In this one platform task, hippocampal HACU, as assessed by the binding of hemicholinium-3 (Ref. 91), is being assessed in the 4 conditions described previously for the one-platform task. The pattern of the data from hippocampal lesions and from hippocampal HACU can indicate if changes in HACU might be an important hip-

pocampal mechanism for plasticity in this task. However, the pattern of behaviorally induced changes in HACU is currently complicated and requires further investigation before any specific conclusions can be drawn about the importance of any particular associative process. Behavioral testing in carefully controlled tasks such as those described here can provide considerable information about the associative and non-associative processes that activate hippocampal PKC and HACU.

In summary, the present experiments introduced variations of spatial and cued discriminations that provide the same experimental control that has been used to examine associative processes in classical conditioning. The impairments produced by the hippocampal lesions indicate that some hippocampal mechanism is necessary for normal performance in the spatial discriminations. The changes in mPKC and HACU suggest that both of these mechanisms may be a component of this hippocampal mechanism. However, additional experiments are necessary to identify the associative and non-associative variables that influence this hippocampal involvement.

9. A snapshot without the album

Howard Eichenbaum, Neal J. Cohen, Tim Otto and Cynthia Wible

9.1. Introduction

Imagine viewing a photograph of some family gathering, say a cookout in the backyard. If you are a member of that family, even this isolated photo will be capable of evoking a sense of familiarity and a (hopefully) heartwarming memory of the occasion captured in the photo. You may well be able to reconstruct many of the events that occurred that day and will likely be reminded of similar events. In remembering these related events, you may find it much like perusing a family photoalbum stored in your memory. The various entries in the 'memory photoalbum' are all interconnected in one way or another; each of them helps trigger related memories of other scenes and events. Thinking about the individual people and places featured in any one of these events will likely remind you of other events and scenes in which they also participated and to which they are also connected. Remembering these various events, you are able to compare and contrast them, noting the continuities and changes across them.

But to someone who is not a member of the family, all you have is a snapshot without the album – just an isolated complex scene that is outside of the temporal and spatial context of your own life's scenes and events. The scene depicted is neither familiar nor connected nor

related to the rich network of your own personal memories. The individual people and places captured in the scene have no independent meaning to you outside of the scene. All in all there is little you can do with the depicted scene with respect to the scenes and events stored in your memory.

Such a 'snapshot without an album' seems to us analogous to memory mediated outside of the hippocampal system, the type of memory that remains preserved in amnesia. There is now abundant evidence that the hippocampal system, whose damage produces a profound amnesia, has a selective role to play in memory, contributing to only one type of memory or one of the brain's memory systems. This system apparently supports the conscious recollection and explicit remembering of facts and events; by contrast, systems outside of hippocampal structures support changes in skilled performance, as seen in skill learning, repetition priming, perceptual adaptations, and conditioning^{29,130,136,137,156}. But it is comparing hippocampal to non-hippocampal *representation* that our analogy of the snapshot comes in. It is our view that the hippocampal system supports *declarative memory*, characterized by a fundamentally *relational* representation in which memories are highly interconnected, can be activated by all manner of inputs and can be ac-

cessed and flexibly expressed in any number of novel contexts. Non-hippocampal systems support *procedural memory* characterized by a *non-relational* form of representation in which memories are functionally independent of one another and inflexibly dedicated to particular processing situations or contexts^{28,131,154}. Tulving and Schacter^{131,154} have written about the 'hyperspecific' nature of such memories. It is this non-relational, inflexible form of representation that seems analogous in some respects to a snapshot without an album.

In the work outlined briefly here, we describe our approach to the issue of hippocampal-system versus non-hippocampal-system memory and the kind of memory representations they support. Our view of the declarative-procedural distinction, together with the goal of identifying parallels in the pattern of impaired and spared learning in humans and animals with hippocampal system damage, had led us to an experimental strategy that involves two stages: First, we train animals with hippocampal system damage on tasks that involve learning specific associations, assessing the learning performance of amnesic subjects versus controls; and second, we probe the representations acquired by these animals during training, assessing just how relational the stored memories are and how flexibly they can be expressed. Animals with damage to the hippocampal-dependent declarative memory system should have only isolated, hyperspecific, inflexible situation-dependent representations and should learn only those tasks for which such representations provide an adequate solution. To determine the general applicability of this experimental strategy we have applied it to two different categories of learning materials: odors and places.

9.2. Hippocampal representation in odor discrimination learning

We have previously shown that hippocampal system damage can result in either impaired or spared learning of identical non-spatial odor discriminations in rats, depending on the representational demands of the learning tasks⁴². After disconnection of the hippocampal system by transection of the fornix, impairment was observed when the discriminative cues were presented simultaneously and in close juxtaposition, encouraging their comparison and a memory representation based on relations between them. In contrast, facilitation of learning after fornix lesions was observed when the same odor cues were presented successively across trials, hindering their comparison and encouraging individual representations for each odor. To assess the nature of memory representation in normal rats and rats with hippocampal system damage, we performed a follow-up experiment using the simultaneous discrimination task⁴⁴. We had ob-

served that even though rats with fornix lesions are usually severely impaired on this task, they occasionally learned new discrimination problems at a normal rate. We exploited this phenomenon and trained pairs of intact rats and rats with fornix lesions on an extensive series of odor discrimination problems, until the rats with fornix transections succeeded in learning two problems at a normal rate. This required presentation of up to 10 problems for some subjects with fornix lesions. When all rats were performing consistently well in overtraining on the instruction problems, we challenged their memory representations with probe trials composed of novel 'mispairings' of the S⁺ odor from one problem with S⁻ odor from the other (Fig. 8). These probes were presented only occasionally, intermingled among frequent repetitions of the original instruction trials. Intact rats performed as well on probe trials as on instruction trials but rats with fornix lesions, while maintaining good performance on repetitions of the instruction trials, performed

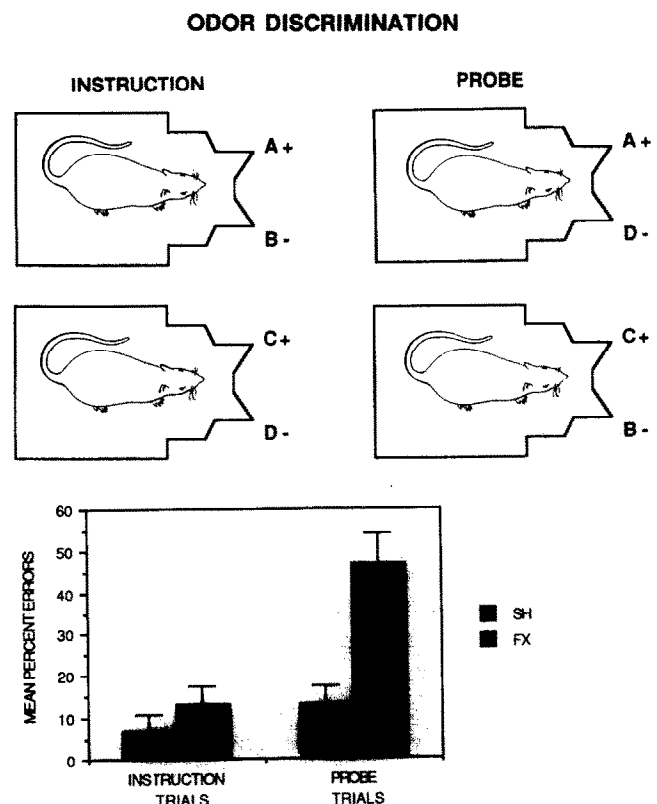

Fig. 8. Assessment of flexible use of odor memory representations. Top: schematic diagrams on the left illustrate examples of trials on two instruction problems (odors A+ vs. B- and C+ vs. D-) that subjects with lesions of the fornix (FX rats) learned as rapidly as sham operated (SH) rats. Flexible use of their representations were assessed by challenging them to identify the same odors 'mispaired' in rare probe trials (examples on right). Bottom: SH and FX rats had low error scores on repetitions of instruction trials and SH rats performed well on probe trials too, but FX rats performed at chance level on the probes. (Taken from Eichenbaum et al. ⁴⁴.)

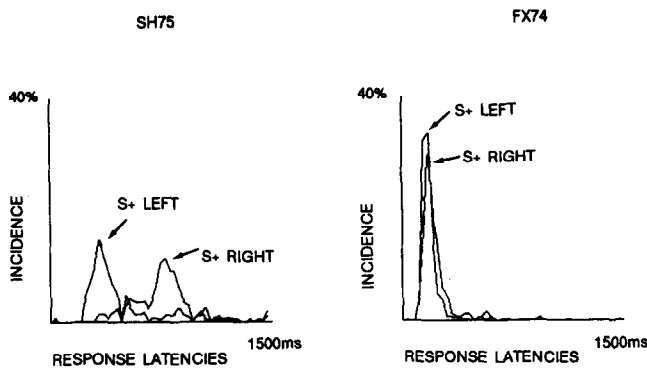

Fig. 9. Assessment of stimulus sampling strategies in an intact rat (SH75) and a rat with a fornix transection (FX74) rat on odor discrimination trials given during overtraining trials where performance was similar for both subjects (87% for SH75 and 84% for FX74). Separate distributions response latencies are shown for correct responses when the S+ odor was presented on the left or on the right. The distribution of response latencies differed for the sham operated rat, depending on where the S+ was presented. In contrast, the response latencies of the FX rat had a single mode more rapid than even the early mode of the sham operated rat. (Taken from Eichenbaum et al.⁴⁴.)

at chance level on the probe trials as if presented with novel stimuli.

Further insight into how the rats with fornix lesions solved simultaneous discrimination problems and the nature of their memory representation was obtained by examining how long rats required to make the discriminative response after presentation of the odor stimuli. Each normal rat had a bimodal distribution of response latencies; the two modes of this distribution could be distinguished by the position of the odors and the response. For example, as shown in Fig. 9, normal rat SH75 responded more rapidly if the S⁺ and the response were on the left than when they were on the right. These findings indicate that normal rats sampled each odor separately, as in the case of SH75 who sampled the left stimulus port first, then the right. In contrast, rats with fornix lesions had abnormally short response latencies and the distribution of latencies was identical regardless of the positions of the odors (e.g., FX74; see Fig. 9). These findings indicate that rats with fornix lesions have a qualitatively different stimulus sampling strategy than normal rats; they appear to sample the two odors at once as a compound stimulus. It might seem unlikely that odor compounds could be distinguished when they differ only by spatial arrangement. Indeed, consistent with the notion that rats with fornix lesions attempt to do so, they usually fail to learn these discrimination problems. (It is notable that they demonstrate the same odor sampling strategy on problems on which they succeed and on those on which they fail.) Perhaps on just those problems when the two compounds can be distinguished perceptually, rats with fornix lesions acquire a separate

stimulus-response association for each compound. If this is the case, one would expect precisely the results observed on the probe trials – the mispaired stimuli do not match any of the odor compounds on which the rats were instructed, so a representation based on encoding distinct compounds would not support recognition of odors in novel pairings. Our findings on odor discrimination led us to conclude that rats with hippocampal system damage tend to acquire an individual association with whatever configuration of stimuli is present at the time of reinforcement and that this kind of representation can only support repetitions of the reinforced behavior. We also postulated that, conversely, normal rats acquire a representation based on *relations* among items in memory and that this kind of memory organization can be identified by its *flexibility*, that is its ability to support the use of memories in situations outside repetition of the learning event.

9.3. Hippocampal representation in place learning

To determine the generality of these properties – *relational representation* and *representational flexibility* – it is important to investigate whether they can account for the pattern of impaired and spared learning capacities in other learning paradigms. In collaboration with Richard Morris, the first author examined the nature of hippocampal representation supporting performance in a water maze task in which rats must use distal visual cues to find the location of a hidden escape platform starting from various starting points¹⁰⁴. On our view, the procedure of releasing animals from different locations introduces conflicts among the individual associations of views along the different trajectories, making it much more advantageous to represent the place of escape according to positional relations among these cues. Consistent with this view, rats with hippocampal system damage are severely impaired in the standard version of this task.

If this account of place learning is valid, it should be possible for rats with hippocampal system damage to succeed in learning guided by the identical place cues if the demand for representing positional relations is eliminated. We circumvented the confusions arising from the variable-start procedure by releasing rats from a constant position on each trial, thus making the association of cues observed along a single trajectory unambiguous. Comparing performance under both conditions, we found that rats with fornix lesions failed to learn the water maze with a variable-start position, but succeeded in place learning guided by the same distal cues in the constant-start condition⁴⁵.

Even though the rats with fornix lesions acquired the constant-start version of the task rapidly, there were two subtle differences in their performance relative to that

of intact rats. First, the learning curve for rats with fornix lesions was more gradual than that of intact rats. Second, rats with fornix lesions, unlike intact rats, occasionally just missed the escape platform, raising their average scores to slightly greater than those of intact rats. These subtle quantitative differences in performance level presaged larger group differences in the qualitative nature of their representations. Nevertheless, by monitoring swim patterns when rats were attempting to locate a missing platform and by observing swim trajectories when cues were moved (see below) or removed, we confirmed that all the rats had employed a representation of distal cues, rather than a motor representation, to identify the place of escape.

Analogous to our strategy in the odor discrimination experiments, we assessed the flexibility of place representations by presenting probe trials that challenged rats to locate the escape site from novel start positions. These probe trials were presented occasionally among frequent repetitions of the instruction trial. Normal rats both performed well on repetitions of the instruction trial given just before each probe trial and swam directly to the escape site from each novel start position. In contrast, rats with fornix lesions, while continuing to perform well on repetitions of the instruction trials, often headed out to the wrong direction and required considerably more time to locate the escape site when starting from a novel position (Fig. 10).

A further observation on the pattern of behavior in rats with fornix lesions gave additional insight into the nature of their place memory representation. We identified two salient cues that were directly in the line of view towards the escape site along the route taken on instruction trials and rotated these cues 180° . On another probe trial using these rotated cues, we also started rats in a position 180° from that of the instruction trials so that, if the rat's behavior was guided only by those particular cues, one would expect it to swim directly across a location corresponding to a 180° rotation of the escape site. Conversely, if the rat's behavior was guided predominantly by the remaining cues, one would expect it to swim directly to the standard escape location. Consistent with the latter prediction, all normal rats swam directly to the original escape location, as they had on the novel start probe trials (Fig. 11). In contrast, the swim pattern of most of the rats with fornix lesions was partially, but not completely, consistent with cue rotation. They headed initially toward the rotated cues but stopped short of the escape location that would be predicted by rotation, then swam in diverse directions. One rat with a fornix lesion behaved completely in accordance with the rotation of cues, swimming directly across the escape location that would be predicted by rotation.

However, two other rats with fornix lesions headed toward neither the trained nor the rotated escape location initially, but seemed 'lost'. These findings indicated that the swim trajectories of normal rats are influenced mainly by the majority of constant cues regardless of start locus. In contrast, most rats with fornix lesions are abnormally dependent on a few salient cues although they do not use these cues exclusively.

9.4. Isolated 'snapshots' preserved in the absence of normal hippocampal system function

The present findings indicate that memories that are successfully acquired by amnesic subjects are robustly demonstrated by them in situations that constitute repetitions of the learning event but are not accessible outside that precise situation. In this way, a non-hippocampal representation is like the snapshot-without-an-album discussed at the outset of this paper, an analogy that the

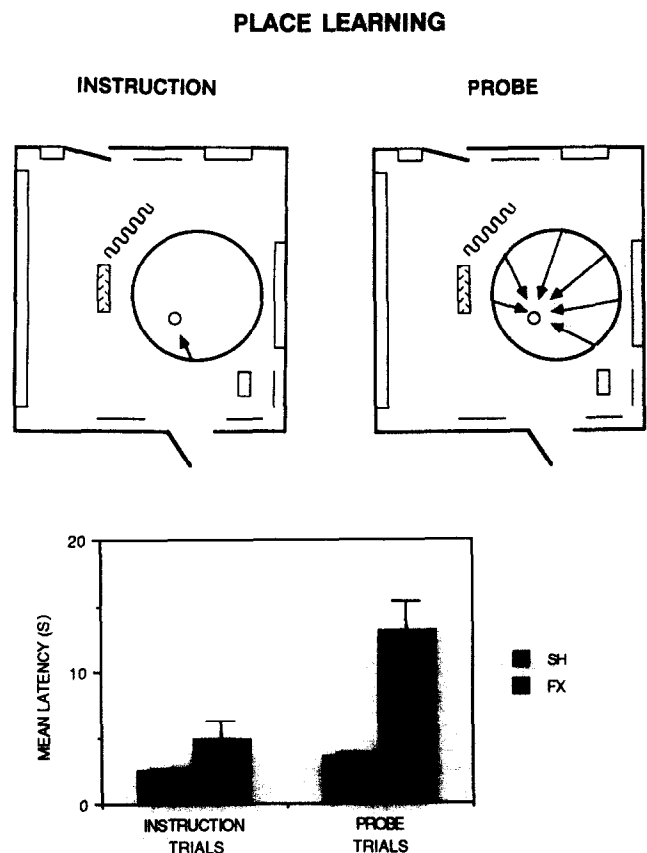

Fig. 10. Assessment of flexible use of place memory representations. Top: as indicated in the schematic diagram of the water maze and test room on the left, rats were instructed to locate the escape site from a constant start locus (arrow). Flexible use of their memory representations was assessed by challenging them to locate the escape site from novel start positions on rare probe trials (right). Bottom: both SH and FX rats had short escape latencies on repetitions of instruction trials and SH rats performed well on probe trials too, but FX rats had elevated escape latencies on the probes. (Taken from Eichenbaum et al.⁴⁵.)

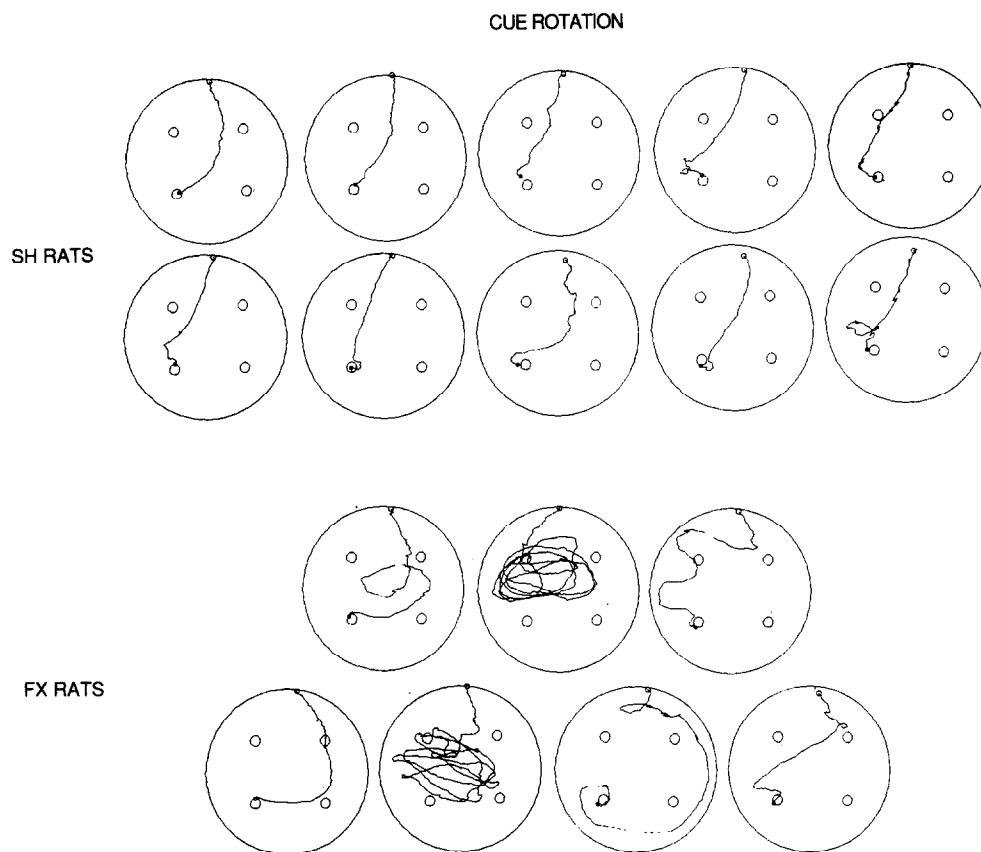

Fig. 11. Assessment of stimulus representation on a probe trial where two salient cues and the start position were rotated 180°. Tracings of individual swim paths for sham operated (SH) rats and rats with fornix lesions (FX) starting this trial from the north (top). The escape position (small circle) predicted by cue-rotation is in the northeast quadrant; the training escape position is in the southwest quadrant. (Taken from Eichenbaum et al.⁴⁵.)

current work suggests can extend to both odor and place learning in rats. It was as if the amnesic rats made a separate and inflexible 'snapshot' of each distinct trial including all of the available cues and the co-occurring response and reinforcer. This kind of memory is clearly enhanced by repetition, but the representation of each event is otherwise not connected to other comparable or contrastable events. Our description of preserved memory as isolated and rigid applies equally well to odor- and place-guided learning in rats with hippocampal system damage and is very similar to Schacter's characterization of preserved memory in human amnesics as 'hyperspecific'. Furthermore, the stimuli guiding behavior in amnesic animals in either paradigm may be quite complex; they can involve compounds of local stimulus elements, as in the simultaneous odor discrimination, or of multiple distal cues, as in place learning in the Morris water maze. That the preserved memories can involve complex or compound items is also characteristic of intact capacities in human amnesia, for example, acquisition of a mirror reading skill or priming of words or pictures^{29,131,137}. Thus our findings suggest that extra-hippocampal

systems may be able to support a normal level of performance on virtually any *individual* association, that is, any problem that is constructed by the subject as an unambiguous association between a stimulus and a rewarded response.

9.5. *The kind of memory representation supported by the hippocampal system*

The main value of investigating the nature of memory representation in animals with hippocampal system dysfunction lies in what we can infer from these findings about the role played by this system in normal memory. Our characterization of preserved snapshot memory in amnesia has significant implications for two related questions about the role of the hippocampal system in normal memory: what is the nature of hippocampal processing in memory and where is the site of permanent memory storage? These two issues will be addressed in turn.

9.5.1. *How does the hippocampal system process memories?* The present findings point to a central contribution of the hippocampal system in the flexible and relational character of normal memory representation.

They suggest that the prime role of the hippocampal system may be to mediate a memory organization that maintains connections between independently acquired memories, permitting access to a set of related memories from the retrieval of any particular memory. Electrophysiological data in intact animals support this hypothesis; these data indicate that the activity of hippocampal principal neurons correlates with processing conjunctions of memory cues, reflecting what might be considered elemental 'connections' between items represented in a memory organization. In olfactory discrimination tasks, some CA1 pyramidal cells fire selectively during the sampling of odor cues. A subset of these fire differentially in relation to the combination of odors and their presentation position in a simultaneous discrimination¹⁶² and in relation to the sequence of odor presentation in a successive odor discrimination⁴³. In spatial memory tasks, hippocampal principal cells fire in relation to the animal's position defined by the spatial relations among multiple environmental cues¹¹⁰. Moreover, the same cells that fire selectively during the sampling of particular odor configurations in the olfactory discrimination task also fire associated with positional cues in a spatial memory task performed in the same environment¹⁶². This observation suggests that the hippocampal system is more closely involved in the processing of 'connections' between items than with detecting or preserving traces of any particular cues or events.

9.5.2. *Where are the memories stored?* The present findings suggest that individual memories need not be stored permanently in the hippocampus, since animals with hippocampal system damage demonstrated memory for individual cues used during training. The same conclusion was reached in studies of the role of the hippocampal system in memory consolidation; these experiments showed that the storage of memories acquired in intact subjects depends on the integrity of the hippocampal system for only a limited period^{132,174}. The hippocampal system might perform its proposed organizational function by maintaining some sort of 'indexing' mechanism for the connections between memories stored elsewhere^{136,151}. Such a hypothesis does not rule out the possibility that the hippocampal system may store memories at least temporarily in the course of its organizational function¹²², consistent with evidence for alterations in hippocampal synaptic efficacy as a result of electrical stimulation^{81,127} that mimics temporal firing patterns occurring naturally in hippocampal cells during critical memory processing events in odor and place memory tasks¹¹⁸.

9.6. *Does the snapshot analogy apply equally well to preserved memory in amnesic monkeys and humans?*

Few studies have applied the use of probe tests to

characterize the nature of preserved memory representation in monkeys or humans with hippocampal system damage. However, one recent experiment somewhat similar in design to our assessment strategy revealed findings in object discrimination learning in monkeys that paralleled our observations on odor and place learning in rats¹²⁹. In this study, intact monkeys and monkeys with damage in the hippocampal system successfully learned to discriminate closely juxtaposed object-pairs composed of different combinations of the same set of objects. In a secondary test phase that served to probe the nature of the acquired representations, monkeys had to select from among 3 separated objects the two that were earlier paired and associated with reward. Intact monkeys could use their experience to make the correct pairings, but monkeys with hippocampal system damage performed at chance. Similar to our observations on odor and place learning in rats, it was as if monkeys with hippocampal system damage had represented each pair of objects as a 'snapshot'; the elements could not be used separately and flexibly in a novel test.

When the knowledge supporting preserved skill learning and priming is probed in human amnesic patients, the inflexibility of their representations for such memory is abundantly clear. For example, Glisky and Schacter's^{54,55} studies on teaching amnesic patients certain job-relevant terms to use on a computer revealed that patients could, after a great deal of painstaking repetitive practice, learn to enter relevant computer commands, but their knowledge was 'hyperspecific' – it could be expressed only when the training conditions were reproduced. Moreover, it has been amply documented that skill learning and repetition priming are so sensitive to changes between training and test conditions that the modality of stimulus presentation and even the specific type font of verbal stimuli become critical variables. Finally, a comprehensive consideration of the snapshot analogy should ask about the performance of human amnesics on memory for snapshots – literally. Memory for pictorial materials, just like that for verbal information, may either be impaired or spared, depending on the degree to which task demands emphasize or circumvent declarative retrieval strategies. Thus memory for pictorial scenes is impaired in human amnesics in standard recognition testing^{69,138}, except under conditions of prolonged exposure⁴⁸. However, when the training conditions are identical to the test conditions and strongly encourage a retrieval strategy that replicates a smooth perceptual identification, even severely amnesic patients demonstrate striking retention of pictorial drawings^{101,157}.

In conclusion, considering the fit of the snapshot analogy to the human literature brings us full circle in the intellectual history of the ideas presented here, for our char-

acterization of declarative and procedural memory in terms of relational representation and representational flexibility comes initially from consideration of the human data. Human amnesic patients have exhibited preserved learning in just those tasks in which relational representation and representational flexibility are not required; i.e., when the task requires only some facilitation of performance in circumstances that constitute repetitions of the original learning situation. Thus they are intact in skill learning, repetition priming, perceptual adaptation and conditioning paradigms in which the same processing operations are repeated between training and testing and there is no need for gaining access to some rich relational structure nor need for flex-

ible use of stored knowledge. In such cases the isolated snapshot supported by extrahippocampal systems is perfectly adequate to guide performance. Thus our characterization of hippocampal-dependent learning in terms of relational representation and representational flexibility may be useful in a general account of the declarative memory system. In particular, we suggest that tests for flexible use of memories can be viewed as operational assessments of hippocampal-system dependent 'declarative' memory across learning paradigms and across species.

Acknowledgements. This work was supported by NIH 1 ROI AG08796 and Office of Naval Research Contract N00014-88-K-0399.

List of participants

Amaral, David

The Salk Institute
P.O. Box 85800
San Diego, CA 92186-5800
U.S.A.

Bear, Mark

Centre for Neural Science
Brown University
Box 1953
Providence, RI 02912
U.S.A.

Bloch, Konrad

Harvard University
Department of Chemistry
12 Oxford Street
Cambridge, MA 02138
U.S.A.

Bloom, Floyd E.

Department of Neuropharmacology
The Scripps Research Institute
10666 North Torrey Pines Road
La Jolla, CA 92037
U.S.A.

Bolis, Liana C.

FESN
4, rue Bellot
1206 Genève
Switzerland

Carew, Thomas J.

Department of Psychology
Yale University

P.O. Box 11A, Yale Station
New Haven, CT 06520
U.S.A.

Disterhoft, John F.

Department of Cell, Molecular and Structural Biology
Northwestern University Medical School
303 East Chicago Avenue
Chicago, IL 60611-3008
U.S.A.

Eichenbaum, Howard

Department of Biological Sciences
Wellesley College
Wellesley, MA 02181
U.S.A.

Feindel, William

Montreal Neurological Institute
3801 University Street
Montreal, Quebec. H3A 2B4
Canada

Gajdusek, Carleton D.

LCNSS, NINDS,
Building 36, Room 5B21
National Institutes of Health
Bethesda, MD 20892
U.S.A.

Lynch, Gary

Center for the Neurobiology of Learning and Memory
University of California
Irvine, CA 92717
U.S.A.

Magistretti, Pierre J.
 Institut de Physiologie
 Université de Lausanne
 7, rue du Bugnon
 1205 Lausanne
 Switzerland

McNaughton, Bruce
 Department of Psychology
 Room 384 Life Sciences North Building
 University of Arizona
 Tucson, AZ 85724
 U.S.A.

Mishkin, Mortimer
 Laboratory of Neuropsychology
 NIMH
 Building 9, Room 1N107
 9000 Rockville Pike
 Bethesda, MD 20892
 U.S.A.

Olton, David S.
 The Johns Hopkins University
 Department of Psychology

Ames Hall
 Baltimore, MD 21218
 U.S.A.

Squire, Larry R.
 University of California at San Diego
 Department of Psychiatry (116)
 Veterans Affairs Medical Center
 3350 La Jolla Village Drive
 San Diego, CA 92161
 U.S.A.

Tosteson, Daniel C.
 Harvard Medical School
 25 Shattuck Street
 Boston, MA 01115
 U.S.A.

Wiesel, Torsten N.
 The Rockefeller University
 Laboratory for Neurobiology
 1230 York Avenue
 New York, NY 10021-6399
 U.S.A.

References

- Alkon, D.L. and Rasmussen, H., A spatial-temporal model of cell activation, *Science*, 239 (1988) 998–1005.
- Alkon, D.L., Changes of membrane currents during learning, *J. Exp. Biol.*, 112 (1984) 95–112.
- Alkon, D.L., *Memory Traces in the Brain*, Cambridge University Press, New York, 1987.
- Alkon, D.L., Naito, S. and Kubota, M., Regulation of hermissenda potassium channels by cytoplasmic and membrane-associated c-kinase, *J. Neurochem.*, 51 (1988) 903–917.
- Alkon, D.L., Sakakibara, M., Foraman, R., Harrigan, J., Lederhandler, I. and Farley, J., Reduction of two voltage-dependent K⁺ currents mediates retention of a learned association, *Behav. Neur. Biol.*, 44 (1985) 278–300.
- Amaral, D.G. and Witter, M.P., The three-dimensional organization of the hippocampal formation: a review of anatomical data, *J. Neurosci.*, 31 (1989) 571–591.
- Ambros-Ingerson, J., Granger, R. and Lynch, G., Simulation of paleocortex performs hierarchical clustering, *Science*, 247 (1990) 1344–1348.
- Andersen, P., Bliss, V.P. and Skrede, K.K., Lamellar organization of hippocampal excitatory pathways, *Exp. Brain Res.*, 13 (1971) 222–238.
- Anderson, J.A., A simple neural network generating an interactive memory, *Math. Biosci.*, 14 (1972) 197–220.
- Anderson, M.L., McPhie, D.L., Staten, L.D. and Alkon, D.L., Imaging of memory-specific changes in the distribution of protein kinase C in the hippocampus, *Science*, 245 (1989) 866–869.
- Arai, A., Larson, J. and Lynch, G., Anoxia reveals a vulnerable period in the development of long-term potentiation, *Brain Res.*, 511 (1990) 353–357.
- Artola, A., Bröcher, S. and Singer, W., Different voltage-dependent thresholds for inducing long-term depression and long-term potentiation in slices of rat visual cortex, *Nature*, 347 (1990) 69–72.
- Bank, B., DeWeer, A., Kuzirian, A.M., Rasmussen, H. and Alkon, D.L., Classical conditioning induces long-term translocation of protein kinase C in rabbit hippocampal CA1 cells, *Proc. Natl. Acad. Sci.*, 85 (1988) 1988–1992.
- Bartus, R.T., Reginald, L.D., Pontecorvo, M.J. and Flicker, C., The cholinergic hypothesis: a historical overview, current perspective, and future directions. In D.S. Olton, E. Gamzu and S. Corkin (Eds.), *Memory Dysfunctions: An Integration of Animal and Human Research from Preclinical and Clinical Perspectives*, The New York Academy of Sciences, New York, 1985, pp. 332–358.
- Bear, M.F. and Colman, H., Binocular competition in the control of geniculate cell size depends upon visual cortical NMDA receptor activation, *Proc. Natl. Acad. Sci. U.S.A.*, 87 (1990) 9246–9249.
- Bear, M.F., Gu, Q., Kleinschmidt, A. and Singer, W., Disruption of experience-dependent synaptic modifications in the striate cortex by infusion of an NMDA receptor antagonist, *J. Neurosci.*, 10 (1990) 909–925.
- Bear, M.F., Involvement of excitatory amino acid receptors in the experience-dependent development of visual cortex. In E.A. Cavalheiro, J. Lehman and L. Turski (Eds.), *Recent Advances in Excitatory Amino Acid Research*, Liss, New York, 1988, pp. 393–401.
- Berger, T.W., Rinaldi, P.C., Weisz, D.J. and Thompson, R.F., Single-unit analysis of different hippocampal cell types during classical conditioning of rabbit nictitating membrane response,

- J. Neurophysiol.*, 50 (1983) 1197-1219.
- 19 Bienenstock, E.L., Cooper, L.N. and Munro, P.W., Theory for the development of neuron selectivity: orientation specificity and binocular interaction in visual cortex, *J. Neurosci.*, 2 (1982) 32-48.
 - 20 Black, J., Disterhoft, J.F. and Yey, J.Z., Dihydropyridine effects on non-activating calcium channels in CA1 neurons, *Soc. Neurosci. Abstr.*, 16 (1990) 510.
 - 21 Byrne, J.H., Cellular analysis of associative learning, *Physiol. Rev.*, 67 (1987) 329-439.
 - 22 Carew, T.J., Cellular and molecular advances in the study of learning in *Aplysia*. In J.P. Changeaux and M. Kinsidhi (Eds.), *The Neural and Molecular Basis of Learning Dahlem Conference*, John Wiley, New York, pp. 177-204.
 - 23 Carew, T.J., Hawkins, R.D. and Kandel, E.R., Differential classical conditioning of a defensive withdrawal reflex in *Aplysia*, *Science*, (1983) 397-400.
 - 24 Carew, T.J., Walters, E.T. and Kandel, E.R., Classical conditioning in a simple defensive withdrawal reflex in *Aplysia*, *J. Neurosci.*, 11 (1981) 1426-1437.
 - 25 Chattarji, S., Stanton, P.K. and Sejnowski, T.J., 2-Amino-3-phosphonopropionate (AP3) blocks induction of associative long-term depression (LTD) in hippocampal field CA1, *Soc. Neurosci. Abstr.*, 16 (1990) 276-320.
 - 26 Clairborne, B.J., Amaral, D.G. and Cowan, W.M., A light and electron microscopic analysis of the mossy fibers of the rat dentate gyrus, *J. Comp. Neurol.*, 246 (1986) 435-458.
 - 27 Clothiaux, E.E., Bear, M.F. and Cooper, L.N., Synaptic plasticity in visual cortex: comparison of theory with experiment, *J. Neurophysiol.*, in press.
 - 28 Cohen, N.J. and Squire, L.R., Preserved learning and retention of a pattern-analyzing skill in amnesia: dissociation of knowing how and knowing that, *Science*, 210 (1980) 207-210.
 - 29 Cohen, N.J., Preserved learning capacity in amnesia: evidence for multiple memory systems. In: N. Butters and L.R. Squire (Eds.), *The Neuropsychology of Memory*, Guilford Press, New York, 1984, pp. 83-103.
 - 30 Cole, G., Dobkins, K.R., Hansen, L.A., Terry, R.D. and Saitoh, T., Decreased levels of protein kinase C in Alzheimer brain, *Brain Res.*, 452 (1988) 165-170.
 - 31 Coulter, D.A., LoTurco, J.J., Kubota, M., Disterhoft, J.F., Morre, J.W. and Alkon, D.L., Classical conditioning reduces the amplitude and duration of the calcium-dependent afterhyperpolarization in rabbit hippocampal pyramidal cells, *J. Neurophysiol.*, 61 (1989) 971-981.
 - 32 Deadwyler, S.A., West, M. and Lynch, G., Activity of dentate granule cells during learning: differentiation of perforant path input, *Brain Res.*, 169 (1979) 29-43.
 - 33 Decker, M.W., Pellemounter, M.A. and Gallagher, M., Effects of training on a spatial memory task on high affinity choline uptake in hippocampus and cortex in young adult and aged rats, *Neuroscience*, 8 (1988) 90-99.
 - 34 De Jonge, M.C., Black, J., Deyo, R.A. and Disterhoft, J.F., Learning-induced afterhyperpolarization reductions in hippocampus are specific for cell type and potassium conductance, *Exp. Brain Res.*, 80 (1990) 456-462.
 - 35 Deyo, R.A., Gabrieli, J.D.E. and Disterhoft, J.F., Human associative learning analysis of trace and delay eye-blink conditioning, *Soc. Neurosci. Abstr.*, 16 (1990) 841.
 - 36 Deyo, R.A., Straube, K. and Disterhoft, J.F., Nimodipine facilitates associative learning in aging rabbits, *Science*, 243 (1989) 809-811.
 - 37 Deyo, R.A., Straube, K.T., Moyer Jr., J.R. and Disterhoft, J.F., Nimodipine ameliorates aging-related changes in open-field behaviors of the rabbit, *Exp. Aging Res.*, 15 (1989) 169-175.
 - 38 Disterhoft, J.F., Coulter, D.A. and Alkon, D.L., Conditioning-specific membrane changes of rabbit hippocampal neurons measures in vitro, *Proc. Natl. Acad. Sci. U.S.A.*, 83 (1986) 2733-2737.
 - 39 Disterhoft, J.F., Golden, D.T., Read, H.R., Coulter, D.A. and Alkon, D.L., AHP reductions in rabbit hippocampal neurons during conditioning are correlated with acquisition of the learned response, *Brain Res.*, 462 (1988) 118-125.
 - 40 Dudek, S.M. and Bear, M.F., A biochemical correlate of the critical period for synaptic modification in kitten visual cortex, *Science*, 246 (1989) 673-675.
 - 41 Dudek, S.M., Bohner, A.P. and Bear, M.F., Effects of AP3 on EAA-stimulated PI turnover and ocular dominance plasticity in the kitten visual cortex, *Neurosci. Abstr.*, 16 (1990) 331-336.
 - 42 Eichenbaum, H., Fagan, A., Mathews, P. and Cohen, N.J., Hippocampal system dysfunction and odor discrimination learning in rats: impairment or facilitation depending on representational demands, *Behav. Neurosci.*, 102 (1988) 331-339.
 - 43 Eichenbaum, H., Kuperstein, M., Fagan, A. and Nagode, J., Cue-sampling and goal-approach correlates of hippocampal unit activity in rats performing an odor-discrimination task, *J. Neurosci.*, 7 (1987) 716-732.
 - 44 Eichenbaum, H., Mathews, P. and Cohen, N.J., Further studies of hippocampal representation during odor discrimination learning, *Behav. Neurosci.*, 103 (1989) 1207-1216.
 - 45 Eichenbaum, H., Stewart, C. and Morris, R.G.M., Hippocampal representation in spatial learning, *J. Neurosci.*, 10 (1990) 3531-3542.
 - 46 Feldman, D., Sherin, J.E., Press, W.A. and Bear, M.F., NMDA stimulated calcium uptake by kitten visual cortex in vitro, *Exp. Brain Res.*, 80 (1990) 252-259.
 - 47 Fox, K., Sato, H. and Daw, N., The location and function of NMDA receptors in cat and kitten visual cortex, *J. Neurosci.*, 9 (1989) 2443-2454.
 - 48 Freed, D.M., Corkin, S. and Cohen, N.J., Forgetting in H.M.: a second look, *Neuropsychologia*, 25 (1987) 461-471.
 - 49 Freeman, W.J. and Schneider, W.S., Changes in spatial patterns or rabbit olfactory EEG with conditioning to odors, *Psychophysiology*, 19 (1982) 44-56.
 - 50 Freeman, W.J. and Van Dijk, B., Spatial patterns of visual cortical fast EEG during conditioned reflex in a rhesus monkey, *Brain Res.*, 422 (1987) 267-276.
 - 51 Frost, W. and Kandel, E.R., Further characterization of interneurons and motor neurons in the siphon withdrawal reflex circuit in *Aplysia californica*, *J. Neurophysiol.*, in press.
 - 52 Gall, C., Sumikawa, K. and Lynch, G., Regional distribution of mRNA for a putative kaninate receptor in rat brain, *Eur. J. Pharmacol.*, 189 (1990) 217-221.
 - 53 Givens, B.S. and Olton, D.S., Cholinergic and GABAergic modulation of medial septal area: effect on working memory, *Behav. Neurosci.*, 104 (1990) 849-855.
 - 54 Glisky, E.L. and Schacter, D.L., Acquisition of domain-specific knowledge in organic amnesia: training for computer-related work, *Neuropsychologia*, 25 (1987) 893-906.
 - 55 Glisky, E.L., Schacter, D.L. and Tulving, E., Computer learning by memory impaired patients: acquisition and retention of complex knowledge, *Neuropsychologia*, 24 (1986) 313-328.
 - 56 Golski, S., Olton, D.S., Mishkin, M., Olds, J.L. and Alkon, D.L., Spatial and cued discriminations: role of the hippocampus and protein kinase C, *Soc. Neurosci. Abstr.*, 16 (1990) 1246.
 - 57 Gormezano, I., Classical conditioning. In J.B. Sidowski (Ed.), *Experimental Methods and Instrumentation in Psychology*, McGraw-Hill, New York, 1966, pp. 385-420.
 - 58 Granger, R., Ambros-Ingerson, J., Staubli, U. and Lynch, G., Memorial operation of multiple, interacting simulated brain structures. In M. Gluck and D. Rumelhart (Eds.), *Neuroscience and Connectionist Theory*, Lawrence Erlbaum, Hillsdale, NJ, 1990, pp. 95-129.
 - 59 Granger, R., Staubli, U., Powers, H., Ambros-Ingerson, J. and Lynch, G., Behavioral test of a prediction from a cortical network simulation, *Psychol. Sci.*, 2 (1991) 116-118.
 - 60 Graves, C.A. and Solomon, P.R., Age-related disruption of

- trace but not delay classical conditioning of the rabbit's nictitating membrane response, *Behav. Neurosci.*, 99 (1985) 88–96.
- 61 Gray, C.M. and Singer, W., Stimulus-specific neuronal oscillations in orientation columns of cat visual cortex, *Proc. Natl. Acad. Sci.*, 86 (1989) 1698–1702.
- 62 Grover, L.M. and Teyler, T.J., Two components of long-term potentiation induced by different patterns of afferent activation, *Nature*, 347 (1990) 477–479.
- 63 Gustafsson, B. and Wigstrom, H., Long-term potentiation in the CA1 region: its induction and early temporal development, *Progr. Brain Res.*, 83 (1990) 223–232.
- 64 Hawkins, R.D., Abrams, T.W., Carew, T.J. and Kandel, E.R., A cellular mechanism of classical conditioning in *Aplysia*: activity-dependent amplification of presynaptic facilitation, *Science*, 219, (1983) 400–405.
- 65 Hawkins, R.D., Castellucci, V.F. and Kandel, E.R., Interneurons involved in mediation and modulation of gill withdrawal reflex in *Aplysia*. I. Identification and characterization, *J. Neurophysiol.*, 45 (1981) 304–314.
- 66 Hawkins, R.D., Clark, G.A. and Kandel, E.R., Cell biological systems of learning in simple vertebrate and invertebrate systems. In F. Plum (Ed.), *Handbook of Physiology, Section I. Higher Functions of the Nervous System, Vol. 6*, American Physiological Society, Bethesda, MD, 1987, pp. 25–83.
- 67 Hollman, M., O'Shea-Greenfield, A., Rogers, S.C. and Heineemann, S., Cloning by functional expression of a member of the glutamate receptor family, *Nature*, 342 (1989) 643–648.
- 68 Holmes, W.R. and Levy, W.B., Insights into associative long-term potentiation from computational models of NMDA receptor-mediated calcium influx and intracellular calcium concentration changes, *J. Neurophysiol.*, 63 (1990) 1148–1167.
- 69 Hubert, F.A. and Piercy, M., Normal and abnormal forgetting in organic amnesia: effects of locus of lesion, *Cortex*, 15 (1979) 385–390.
- 70 Huynh, T.V., Cole, G., Katzman, R., Huang, K-P. and Saitoh, T., Reduced PKC immunoreactivity and altered protein phosphorylation in Alzheimer's disease fibroblasts, *Arch. Neurol.*, 43 (1989) 1195–1199.
- 71 Ishizuka, N., Weber, J. and Amaral, D.G., Organization of intrahippocampal projections originating from CA3 pyramidal cells in the rat, *J. Comp. Neurol.*, 295 (1990) 580–623.
- 72 Jung, M.W., Larson, J. and Lynch, G., Long-term potentiation of monosynaptic EPSPs in the piriform cortex in vitro, *Synapse*, 6 (1990) 279–283.
- 73 Katzman, R., Alzheimer's disease, *New Engl. J. Med.*, 314 (1986) 964–973.
- 74 Khachaturian, Z.S., Towards theories of brain ageing. In D.W. Kay and G.D. Burrows (Eds.), *Handbook of Studies in Psychiatry and Old Age*, Elsevier, New York, 1984, pp. 7–30.
- 75 Kleinschmidt, A., Bear, M.F. and Singer, W., Blockade of 'NMDA' receptors disrupts experience-dependent modifications of kitten striate cortex, *Science*, 238 (1987) 355–358.
- 76 Kohonen, T., *Associative Memory: A System-Theoretic Approach*, Springer-Verlag, New York, 1978.
- 77 Komisaruk, B.R., Synchrony between limbic system theta activity and rhythmical behavior in rats, *J. Comp. Physiol. Psychol.*, 70 (1970) 482–492.
- 78 Krontiris-Litowitz, J.K., Erikson, M.T. and Walters, E.T., Central suppression of defensive reflexes in *Aplysia* by noxious stimulation and by factors released by the body wall, *Soc. Neurosci. Abstr.*, 13 (1987) 815.
- 79 Landfield, P.W. and Pitler, T.A., Prolonged Ca²⁺-dependent afterhyperpolarizations in hippocampal neurons of aged rats, *Science*, 226 (1984) 1089–1092.
- 80 Landfield, P.W., Nimodipine modulation of aging-related increases in hippocampal calcium currents. In J. Traber and W.H. Gispen (Eds.), *Nimodipine and Central Nervous System Function: New Vistas*, Schattauer, Stuttgart, 1989, pp. 227–238.
- 81 Larson, J. and Lynch, G., Induction of synaptic potentiation in hippocampus by patterned stimulation involves two events, *Science*, 232 (1986) 985–988.
- 82 Larson, J. and Lynch, G., Role of N-methyl-D-aspartate receptors in the induction of synaptic potentiation by burst stimulation patterned after the hippocampal theta rhythm, *Brain Res.*, 441 (1988) 111–118.
- 83 Larson, J. and Lynch, G., Theta pattern stimulation and the induction of LTP: the sequence in which synapses are stimulated determines the degree to which they potentiate, *Brain Res.*, 489 (1989) 49–58.
- 84 Lisman, J.E., A mechanism for the Hebb and anti-Hebb processes underlying learning and memory, *Proc. Natl. Acad. Sci. U.S.A.*, 86 (1989) 9574–9578.
- 85 Loturco, J.J., Coulter, D.A. and Alkon, D.L., Enhancement of synaptic potential in rabbit CA1 pyramidal neurons following classical conditioning, *Proc. Natl. Acad. Sci.*, 85 (1988) 1672–1676.
- 86 Lynch, G. and Baudry, M., Structure-function relationships in the organization of memory. In M. Gazzaniga (Ed.), *Perspectives in Memory Research*, MIT Press, Cambridge, 1988, pp. 23–91.
- 87 Lynch, G. and Granger, R., Simulation and analysis of a simple cortical network, *Psychol. Learn. Motiv.*, 23 (1989) 205–241.
- 88 Lynch, G., Larson, J., Muller, D. and Granger, R., Neural networks and networks of neurons. In J.L. McGaugh, N. Weinberger and G. Lynch (Eds.), *Brain Organization and Memory: Cells, Systems, and Circuits*, Oxford University Press, New York, 1990, pp. 390–400.
- 89 Lynch, G., *Synapses, Circuits and the Beginning of Memory*, MIT Press, Cambridge, MA, 1986.
- 90 Mackey, S.L., Glanzman, D.L., Small, S.A., Dyke, A.M., Kandel, E.R. and Hawkins, R.D., Aversive stimuli produce inhibition as well as sensitization of the siphon withdrawal reflex of *Aplysia*: a possible behavioral role for presynaptic inhibition mediated by the peptide FMRFamide, *Proc. Natl. Acad. Sci. U.S.A.*, 84 (1987) 8730–8734.
- 91 Manaker, S., Wiczorek, C.M. and Rainbow, T.C., Identification of sodium-dependent, high-affinity choline uptake sites in rat brain with [³H]hemicholinium-3, *J. Neurochem.*, 46 (1986) 483–488.
- 92 Marcus, E.A., Nolen, T.G., Rankin, C.H. and Carew, T.J., Behavioral dissociation of dishabituation, sensitization, and inhibition in *Aplysia*, *Science*, 241 (1988) 210–213.
- 93 Marcus, E.A., Nolen, T.G., Rankin, C.H. and Carew, T.J., Behavioral dissociation of dishabituation, sensitization and inhibition in the siphon withdrawal reflex of adult *Aplysia*, *Soc. Neurosci. Abstr.*, 13 (1987) 816.
- 94 Marr, D., Simple memory: a theory for archicortex, *Philos. Trans. R. Soc. (Biol)*, 262 (1971) 23–81.
- 95 Masliah, E., Cole, G., Shimohama, S., Hansen, L. and DeTeresa, R., Differential involvement of protein kinase C isozymes in Alzheimer's disease, *J. Neurosci.*, 10 (1990) 2113–2124.
- 96 McNaughton, B.L. and Barnes, C.A., From cooperative synaptic enhancement to associative memory: bridging the abyss. In *Seminars in the Neurosciences*, H. Wigström and B. Gustafsson (Eds.), W.B. Saunders, London, in press.
- 96a McNaughton, B.L., Leonard, B.J. and Chen, L., Cortical-hippocampal interactions and cognitive mapping: a hypothesis based on reintegration of the parietal and inferotemporal pathways for visual processing, *Psychobiology*, 17 (1989) 230–235.
- 97 McNaughton, B.L. and Morris, R.G.M., Hippocampal synaptic enhancement and information storage within a distributed memory system, *TINS*, 10 (1987) 408–415.
- 98 McNaughton, B.L. and Nadel, L., Hebb-Marr networks and the neurobiological representation of action in space. In M.A. Gluck and D.E. Rumelhart (Eds.), *Neurosciences and Connectionist Theory*, Lawrence Erlbaum, Hillsdale, NJ, 1990, pp. 1–63.

- 99 McNaughton, B.L., Barnes, C.A., Rao, G., Baldwin, J. and Rasmussen, M., Long-term enhancement of hippocampal synaptic transmission and the acquisition of spatial information, *J. Neurosci.*, 6 (1986) 563–571.
- 100 McNaughton, B.L., Long-term synaptic enhancement and short-term potentiation in rat fascia dentata act through different mechanisms, *J. Physiol.*, 324 (1982) 249–262.
- 101 Milner, B., Corkin, S. and Teuber, H.-L., Further analysis of the hippocampal amnesic syndrome: a 14-year follow-up study of H.M., *Neuropsychologia*, 6 (1968) 215–234.
- 102 Mizumori, S.J.Y., McNaughton, B.L., Barnes, C.A. and Fox, K.B., Preserved spatial coding in hippocampal CA1 pyramidal cells during reversible suppression of CA3c output: evidence for pattern completion in hippocampus, *J. Neurosci.*, 9 (1989) 3915–3928.
- 103 Monaghan, D.T. and Cotman, C., Distribution of *N*-methyl-D-aspartate sensitive L-[³H]glutamate binding sites in rat brain, *J. Neurosci.*, 11 (1985) 2909–2919.
- 104 Morris, R.G.M., Garrud, F., Rawlins, J.N.P. and O'Keefe, J., Place navigation impaired in rats with hippocampal lesion, *Nature*, 297 (1982) 681–683.
- 105 Morris, R.G.M., Spatial localization does not require the presence of local cues, *Learn. Motiv.*, 12 (1981) 239–260.
- 106 Moyer Jr., J.R., Black, J. and Disterhoft, J.F., Effects of nimodipine on rabbit CA1 hippocampal neurons, *Soc. Neurosci. Abstr.*, 16 (1990) 510.
- 107 Moyer Jr., J.R., Deyo, R.A. and Disterhoft, J.-F., Hippocampectomy disrupts trace eye-blink conditioning in rabbits, *Behav. Neurosci.*, 104 (1990) 243–252.
- 108 Muller, D. and Lynch, G., Evidence that changes in presynaptic calcium currents are not responsible for long-term potentiation in hippocampus, *Brain Res.*, 479 (1989) 290–299.
- 109 Nakst, I., Avendano, C., Morrison, J.H. and Amaral, D.G., An experimental analysis of the origins of the somatostatin immunoreactive fibers in the dentate gyrus of the rat, *J. Neurosci.*, 6 (1986) 1452–1462.
- 110 O'Keefe, J. and Conway, D.H., Hippocampal place units in the freely moving rat: why they fire when they fire, *Exp. Brain Res.*, 31 (1978) 573–590.
- 111 O'Keefe, J. and Speakman, A., Single unit activity in the rat hippocampus during a spatial memory task, *Exp. Brain Res.*, 68 (1987) 1–27.
- 112 Olds, J.L., Golski, S., McPhie, D.L., Olton, D.S., Mishkin, M. and Alkon, D.L., Discrimination learning alters the distribution of protein kinase C in the hippocampus of rats, *J. Neurosci.*, 10 (1990) 3707–3713.
- 113 Olton, D.S. and Wenk, G.L., Dementia: animal models of the cognitive impairments produced by degeneration of the basal forebrain cholinergic system. In H.Y. Meltzer (Ed.), *Psychopharmacology: The Third Generation of Progress*, 1987, Raven Press, New York, pp. 941–953.
- 114 Olton, D.S., Givens, B.S., Markowska, A.L., Shapiro, M., Golski, S. and Gorman, L., Mnemonic functions of the septo-hippocampal system. In *Memory: Organization and Locus of Change*, L.R. Squire, G. Lynch, L.R. Weinberger and J.L. McGaugh, (Eds.), Oxford University Press, London, in press.
- 115 Olton, D.S., Markowska, A.L. and Voytko, M.L., Basal forebrain cholinergic system: a functional analysis. In T.C. Napier, P.W. Kalivas and I. Hanin (Eds.), *The Basal Forebrain: Anatomy to Function*, Plenum Press, New York, 1991, pp. 247–262.
- 116 Olton, D.S., Markowska, A.L., Breckler, S.J., Wenk, G.L., Pang, K.C., Koliatsos, V. and Price, D.L., *Individual Differences in Aging: Behavioral and Neural Analyses. Biomedical and Environmental Sciences*, in press.
- 117 Olton, D.S., Wenk, G.L. and Markowska, A.M., Basal forebrain, memory, and attention. In R. Richardson (Ed.), *Activation to Acquisition: Functional Aspects of the Basal Forebrain*, Birkhauser, Boston, MA, 1991, 247–262.
- 118 Otto, T., Eichenbaum, H., Wiener, S. and Wible, C., Learning-related patterns of CA1 spike trains parallel stimulation parameters optimal for inducing hippocampal long-term potentiation, *Hippocampus*, 1 (1991) 181–192.
- 119 Perez, G.M., Barnes, C.A. and McNaughton, B.L., Effects of medial septal inactivation on multiple unit activity in the subiculum and entorhinal cortex of anesthetized rats, *Soc. Neurosci. Abstr.*, 16 (1990) 442.
- 120 Quirk, G.J., Muller, R.U. and Kubie, J.L., The firing of hippocampal place cells in the dark depends on the rat's recent experience, *J. Neurosci.*, 10 (1990) 2008–2017.
- 121 Racine, R.J., Milgram, N.W. and hafner, S., Long-term potentiation phenomena in the rat limbic forebrain, *Brain Res.*, 260 (1983) 217–231.
- 122 Rawlins, J.N.P., Associations across time: the hippocampus as a temporary memory store, *Brain Behav. Sci.*, 8 (1985) 479–496.
- 123 Reynolds, I.J. and Bear, M.F., NMDA receptor development in the visual cortex of cats, *Neurosci. Abstr.*, 15 (1989) 4–7.
- 124 Ribak, C.E., Seress, L. and Amaral, D.G., The development, ultrastructure and synaptic connections of the mossy cells of the dentate gyrus, *J. Neurocytol.*, 14 (1985) 835–857.
- 125 Roman, F., Staubli, U. and Lynch, G., Evidence for synaptic potentiation in a cortical network during learning, *Brain Res.*, 418 (1987) 221–226.
- 126 Rose, G., Diamond, D. and Lynch, G., Dentate granule cells in the rat hippocampal formation have the behavioral characteristics of theta neurons, *Brain Res.*, 266 (1983) 29–37.
- 127 Rose, G.M. and Dunwiddie, T.V., Induction of hippocampal long-term potentiation using physiologically patterned stimulation, *Neurosci. Lett.*, 69 (1986) 244–248.
- 128 Sanchez-Andres, J.V. and Alkon, D.L., Voltage-clamp analysis of the effects of classical conditioning in hippocampus, *J. Neurophysiol.*, in press.
- 129 Saunders, R.C. and Weiskrantz, L., The effects of fornix transection and combined fornix transection, mammillary body lesions and hippocampal ablations on object pair association memory in the rhesus monkey, *Behav. Brain Res.*, 35 (1989) 85–94.
- 130 Schacter, D.L., Implicit memory: history and status, *J. Exp. Psychol. Learn. Mem. Cogn.*, 13 (1987) 501–518.
- 131 Schacter, D.L., Multiple forms of memory in humans and animals. In N.M. Weinberger, J.L. McGaugh and G. Lynch (Eds.), *Memory Systems of the Brain*, Guilford Press, New York, 1985, pp. 351–380.
- 132 Scoville, W.B. and Milner, B., Loss of recent memory after bilateral hippocampal lesions, *J. Neurol. Neurosurg. Psychiatry*, 20 (1957) 11–12.
- 133 Scriabine, A., Schuurman, T. and Traber, J., Pharmacological basis for the use of nimodipine in central nervous system disorders, *FASEB J.*, (1989) 1799–1806.
- 134 Squire, L.R. and Cohen, N.J., Human memory and amnesia. In G. Lynch, J.L. McGaugh and N.M. Weinberger (Eds.), *Neurobiology of Learning and Memory*, 1984, pp. 3–64.
- 135 Squire, L.R. and Zola-Morgan, S., Memory: brain systems and behavior, *Trends Neurosci.*, 11 (1988) 170–175.
- 136 Squire, L.R., Cohen, N.J. and Nadel, L., The medial temporal region and memory consolidation: a new hypothesis. In H. Weingartner and E.S. Parker (Eds.), *Memory Consolidation*, L. Erlbaum, Hillsdale, 1984, pp. 185–210.
- 137 Squire, L.R., *Memory and Brain*, Oxford University Press, New York, 1987.
- 138 Squire, L.R., Two forms of amnesia: an analysis of forgetting, *J. Neurosci.*, 1 (1981) 635–640.
- 138a Squire, L.R., Mishkin, M. and Shimamura, A. (Eds.), Report of the Seventh FESN Study Group on 'Learning and Memory', *Discussions in Neuroscience, Vol. VI, Issue 3+4*, Elsevier, Amsterdam, 1989.
- 139 Standing, L., Learning 10,000 pictures, *Q. J. Exp. Psychol.*, 25 (1973) 207–222.
- 140 Staubli, U. and Lynch, G., Stable hippocampal long-term potentiation elicited by theta pattern stimulation, *Brain Res.*, 435

- (1987) 227–234.
- 141 Staubli, U., Faraday, R. and Lynch, G., Pharmacological dissociation of memory: anisomycin, a protein synthesis inhibitor, and leupeptin, a protease inhibitor, block different learning tasks, *Behav. Neural Biol.*, 43 (1985) 287–297.
 - 142 Staubli, U., Fraser, D., Faraday, R. and Lynch, G., Olfaction and the 'data' memory system in rats, *Behav. Neurosci.*, 101 (1987) 757–765.
 - 142a Staubli, U., Fraser, D., Kessler, M. and Lynch, G., Studies on retrograde and anterograde amnesia of olfactory memory after denervation of the hippocampus by entorhinal cortex lesions, *Behav. Neural Biol.*, 46 (1986) 432–444.
 - 143 Staubli, U., Larson, J. and Lynch, G., Mossy fiber potentiation and long-term potentiation involve different expression mechanisms, *Synapse*, 5 (1990) 333–335.
 - 144 Staubli, U., Larson, J., Thibault, O., Baudry, M. and Lynch, G., Chronic administration of a thiol-proteinase inhibitor blocks long-term potentiation of synaptic responses, *Brain Res.*, 444 (1988) 153–158.
 - 145 Staubli, U., Thibault, O., DiLoreanzo, M. and Lynch, G., Antagonism of NMDA receptors impairs acquisition but not retention of olfactory memory, *Behav. Neurosci.*, 103 (1989) 54–60.
 - 146 Steward, O., Topographic organization of the projections from the entorhinal cortex to the hippocampal formation of the rat, *J. Comp. Neurol.*, 167 (1976) 285–314.
 - 147 Straube, K.T., Deyo, R.A., Moyer Jr., J.R. and Disterhoft, J.F., Dietary nimodipine improves associative learning in aging rabbits, *Neurobiol. Aging*, 11 (1990) 659–661.
 - 148 Stripling, J.S., Patneau, D.K. and Gramlich, G.A., Selective long-term potentiation in the pyriform cortex, *Brain Res.*, 441 (1988) 281–291.
 - 149 Suzuki, W.A. and Amaral, D.G., Cortical inputs to the CA1 field of the monkey hippocampus originate from the perirhinal and parahippocampal cortex but not from area TE, *Neurosci. Lett.*, 115 (1990) 43–48.
 - 150 Tamamaki, N., Abe, K. and Nojyo, Y., Columnar organization in the subiculum formed by axon branches originating from single CA1 pyramidal neurons in the rat hippocampus, *Brain Res.*, 412 (1987) 156–160.
 - 151 Teyler, T.J. and DiScenna, P., The hippocampal memory indexing theory, *Behav. Neurosci.*, 100 (1986) 147–154.
 - 152 Thompson, L.T., Deyo, R.A. and Disterhoft, J.F., Nimodipine enhances spontaneous activity of hippocampal pyramidal neurons in aging rabbits at a dose that facilitates learning, *Brain Res.*, 535 (1990) 190–193.
 - 153 Toumane, A., Durkin, T., Marighetto, A. and Jaffard, R., The durations of hippocampal and cortical cholinergic activation induced by spatial discrimination testing of mice in an eight-arm radial maze decrease as a function of acquisition, *Behav. Neural Biol.*, 52 (1989) 279–284.
 - 154 Tulving, E. and Schacter, D.L., Priming and human memory systems, *Science*, 247 (1990) 301–306.
 - 155 Van der Kerckhoff, W. and Drewes, L.R., Transfer of nimodipine and another calcium antagonist across the blood-brain barrier and their regional distribution in vivo. In M. Bergener and B. Reisberg (Eds.), *Diagnosis and Treatment of Senile Dementia*, Springer-Verlag, Berlin, 1989, pp. 308–321.
 - 156 Warrington, E.K. and Weiskrantz, L., Amnesia: a disconnection syndrome?, *Neuropsychologia*, 20 (1982) 233–248.
 - 157 Warrington, E.K. and Weiskrantz, L., New method for testing long-term retention with special reference to amnesic patients, *Nature*, 217 (1968) 972–974.
 - 158 Wehner, J.M., Sleight, S. and Upchurch, M., Relationship of hippocampal protein kinase C activity to spatial learning performance, *Soc. Neurosci. Abstr.*, 15 (1990) 1170.
 - 159 Wehner, J.M., Sleight, S. and Upchurch, N., Hippocampal protein kinase C activity is reduced in poor spatial learners, *Brain Res.*, 523 (1990) 181–187.
 - 160 Wenk, G., Hepler, D. and Olton, D., Behavior alters the uptake of [³H]choline into acetylcholinergic neurons of the nucleus basalis magnocellularis and medial septal area, *Behav. Brain Res.*, 13 (1984) 129–138.
 - 161 Wetenbroek, R.E., Ahljianian, M.K. and Caterall, W.A., Clustering of L-type Ca²⁺ channel at the base of major dendrites in hippocampal pyramidal neurons, *Nature*, 347 (1990) 281–284.
 - 162 Wiener, S.I., Paul, C.A. and Eichenbaum, H., Spatial and behavioral correlates of hippocampal neuronal activity, *J. Neurosci.*, 9 (1989) 2737–2763.
 - 163 Willshaw, D.J., *Models of Distributed Associative Memory*, doctoral dissertation, University of Edinburgh (unpublished results).
 - 164 Witter, M.P., Ostendorf, R.H. and Groenewegen, H.J., Heterogeneity in the dorsal subiculum of the rat. Distinct neuronal zones project to different cortical and subcortical targets, *Eur. J. Neurosci.*, 2 (1990) 718–725.
 - 165 Wong, K.L., Murakami, K. and Routtenberg, A., Dietary cis-fatty acids that increase protein F1 phosphorylation enhance spatial memory, *Brain Res.*, 505 (1989) 302–305.
 - 166 Woodruff-Pak, D.S. and Thompson, R.F., Classical conditioning of the eyelid response in rabbits as a model system for the study of brain mechanisms of learning and memory in aging, *Exp. Aging Res.*, 11 (1985) 109–122.
 - 167 Woolf, N.J., Eckenstein, F. and Butcher, L.L., Cholinergic systems in the rat brain. I. Projections to the limbic telencephalon, *Brain Res. Bull.*, 13 (1984) 751–784.
 - 168 Worley, P.F., Baraban, J.M., De Souza, E.B. and Snyder, S.H., Mapping second messenger systems in the brain: differential localizations of adenylate cyclase and protein kinase C, *Proc. Natl. Acad. Sci.*, 83 (1986) 4053–4057.
 - 169 Worley, P.F. and Baraban, J.M., Heterogeneous localization of protein kinase C in rat brain: autoradiographic analysis of phorbol ester receptor binding, *J. Neurosci.*, 6 (1986) 199–207.
 - 170 Wright, W. and Carew, T.J., Contribution of interneurons to tail shock induced inhibition of the siphon withdrawal reflex of *Aplysia*, *Soc. Neurosci. Abstr.*, 16 (1990) 20.
 - 171 Yeckel, M.F. and Berger, T.W., Feedforward excitation of the hippocampus by afferents from the entorhinal cortex: redefinition of the role of the trisynaptic pathway, *Proc. Natl. Acad. Sci. U.S.A.*, 87 (1990) 5832–5836.
 - 172 Youngentob, S.L., Mozell, M.M., Sheebe, P.R. and Hornung, D.E., A quantitative analysis of sniffing strategies in rats performing odor detection tasks, *Physiol. Behav.*, 41 (1987) 59–69.
 - 173 Zalutsky, R.A. and Nicoll, R.A., Comparison of two forms of long-term potentiation in single hippocampal neurons, *Science*, 240 (1990) 1619–1624.
 - 174 Zola-Morgan, S.M. and Squire, L.R., The primate hippocampal formation: evidence for time-limited role in memory storage, *Science*, 250 (1990) 288–290.